

# FCIA DIIM & Firestopping Chapter 1 – DIIM & Testing

18 February 2015





# Contacts

Firestop Contractors International Association

Hillside, IL – +1-708-202-1108 - office

Bill McHugh – bill @ fcia.org

# Learning Objectives

Upon completing this program, the participant should know how to:

1. Recognize Perimeter Fire Containment, Penetration, Joint Product Design/Testing, **Installation & Inspection & Management** Standards & Code Requirements for Firestopping ... to become a 'System'.
2. Focus on Perimeter Fire Containment for Curtainwalls
3. Understand Requirements for Firestopping for Safety in the US and Canada
4. Section 07 84 00++ Highlights
5. Learn about 'Why compartmentation and Firestopping'.

# Details

- 1 Hour Webinar – AIA Credits!
- Questions
- Join FCIA!
- Firestop Containment Worker Education
- FCIA ECA Conference -Dallas

# “DIIM”

- Firestopping for Safety – DIIM
  - Properly *Designed* and Specified Firestopping  
FCIA - 07-84-00 - Specification
  - *Tested and Listed Systems* - ASTM E 814 / UL 1479 - UL 2079, ULC-S-115, ASTM E2307
  - Professional *Installation* – FCIA Member, FM 4991 Approved, UL Qualified Contractors
  - Properly *Inspected* - ASTM E 2174 / 2393  
Protocol by IAS AC 291 Accreditation Criteria  
for Inspection Agencies
  - *Maintained* (Annually - FCIA Members – NFPA 101, International Fire Code

# Firestop Contractors International Association

- FCIA – Worldwide Association
- Firestop Contractors, Manufacturers, Consultants, Reps, Distributors,
- Life Safety Digest
- FCIA Website Resources - FREE
- FCIA MOP on PDF FREE to Specifiers, Architects, Governmental Bldg./Fire Officials, worldwide..
  - [www.fcia.org](http://www.fcia.org)

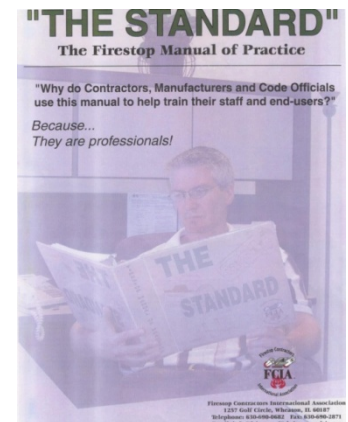
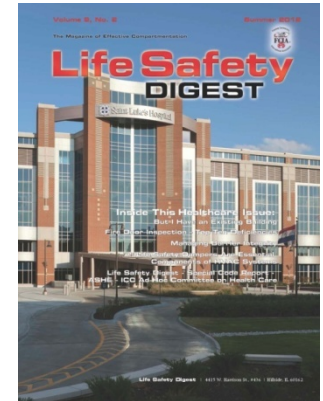

# “TOTAL FIRE PROTECTION”

- Effective Compartmentation
  - Fire Barriers, Fire Walls/Floors, Smoke Barriers
  - Firestopping, Fire Dampers, Swinging and Rolling Fire Doors, Fire Rated Glazing
- Detection & Alarm Systems
- Sprinkler Suppression Systems
- Education & Egress—
  - Building Owners & Managers, Building Occupants and Firefighters

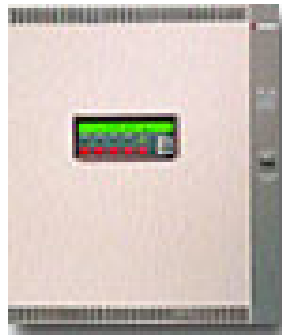

# Building & Fire Code Requirements

- NFPA 5000 – 101- Chapter 8
- National Building Code – Canada
- UAE Fire and Life Safety Code – Chapter
- International Codes –
  - New and Existing Buildings International Building Code – Chapter 7
  - International Fire Code – Chapter 7
- *Minimum requirements - Construction*





# Building & Fire Code Requirements

- Compartmentation Codes – US –
  - **Fire Resistance** – Time, in minutes or hours that materials or assemblies have withstood a fire exposure as determined by tests, methods based on tests, or this code .... NFPA, Ch 8. **ICC adds... “Systems”**

# Building & Fire Code Requirements

- Compartmentation Codes – US –
  - *Exterior Walls*
  - *Fire Walls*
  - *Fire Barriers*
  - *Fire Partitions (Not NFPA)*
  - *Smoke Barriers*
  - *Smoke Partitions*

# Building & Fire Code Requirements

- Compartmentation Codes – US –
  - *Continuity*
  - *Openings & Penetrations*
  - *Robustness*

# Building & Fire Code Requirements

- Fire Barriers
  - Fire Area Separations
  - Mixed Use Occupancies
  - Incidental Uses
  - Hazardous Area Separations
  - Exit Enclosures
  - Shaft enclosures
  - Horizontal Exits
  - Corridor Walls - NFPA

# Building & Fire Code Requirements

- Smoke Barriers
  - Healthcare
  - Other Occupancies
- NFPA 101 - no quantified L Rating for Firestops
- IBC – Quantified L Rating for Firestops

# Building & Fire Code Requirements

- Compartmentation Codes – US
  - **Smoke Barrier – Firestopping** for Continuity
    - IBC – Hourly Rated, “L” Rating
      - <5cfm/sf (IBC 2006)
      - < 50 cfm, 100sf of Wall Area (IBC 2009)
    - **NFPA** – ... ‘restricting the passage of smoke’ ...  
**no quantified “L” Rating ... YET**
      - Continuous, Barrier to Barrier, ... through concealed spaces,
      - Not always fire resistance rated.
  - **Smoke Partition**
    - IBC – Continuous barrier, not rated... ‘retard’.
    - NFPA – Continuous membrane that is designed to form a barrier to *limit the transfer of smoke*....

# Building & Fire Code Requirements

- *Chemical, Biological, Radiation, Explosion, etc.*
  - **Standards?**
    - **R - Nuclear Power Plant Standards**
    - **E – Blast Strength? Check with manufacturer – 2psf**
    - **C – Which Chemicals? Check with manufacturer**
    - **B – Which Agents? Check with manufacturer**
    - **G – Germ – Check with manufacturer & industrial hygienist**
  - **How to Regulate for Unexpected Events?**
  - **Due Diligence - Review Required by code?**

# Buildings are Safe Because....

- *Total Fire Protection Stats -  
North America High Rise*
  - *11,025 Tall Buildings - 20 + stories*
  - *70% in NY, SF, LA, CHI, HI, Toronto...*
    - *2/3 Canada's high rise built before 1985*
- = Compartmentation Primary in Older Structures*
- *Chicago, NY, Toronto – Older stock of buildings*
  - *SF, LA, HON – Earthquakes*

» *Source, Emporis.com*





# Buildings are Safe Because....

- *Total Fire Protection*  
= *Safer buildings...*
- *Compartmentation*
- *Sprinklers, Alarms,*
- *Egress Strategies*
- *NIST Reports...*



# Buildings are Safe Because....

- **National Institute of Standards & Technology**  
**‘NIST Reports - World Trade Center 7 –**
- **Chapter 4.6, 'Factors that could have mitigated structural collapse'**
  - *“..improved compartmentation in tenant areas to limit the spread of fires‘*
- *‘But first...DIIM’*



# Continuity – Barriers, Walls & Horizontal Assemblies

- Fire Walls and Floors –

- *Continuous Fire Resistance Rated Assemblies*

- Concrete
    - Concrete Block
    - Plaster
    - Gypsum Block
    - Gypsum Board / ‘Drywall’
    - Floor/Ceiling Assemblies
    - Firestop Systems

***“Tested & Listed Wall/Floor Systems”***



# Continuity

## Effective Compartmentation Features

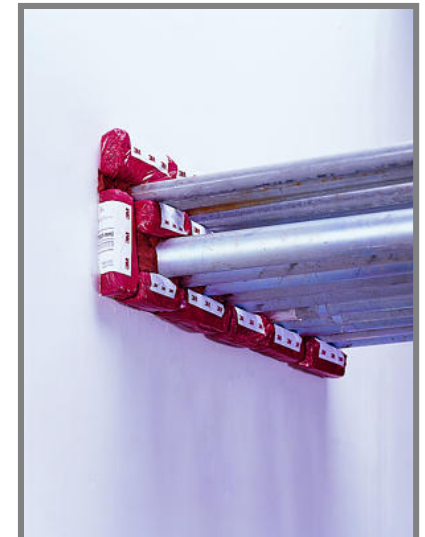

# Firestopping for Continuity

## I – Listed Systems

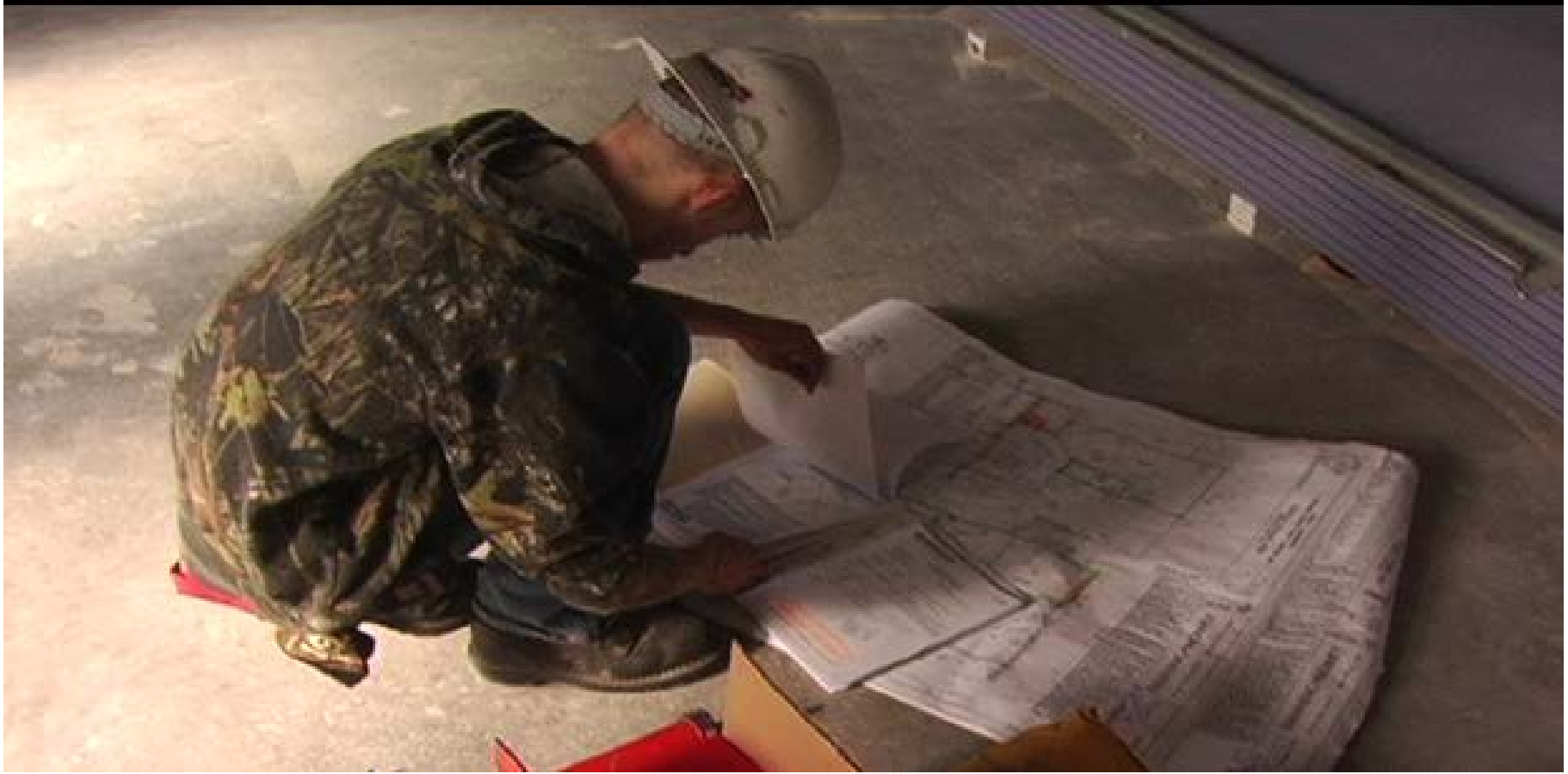

# Firestopping for Continuity

## I – Classified Systems

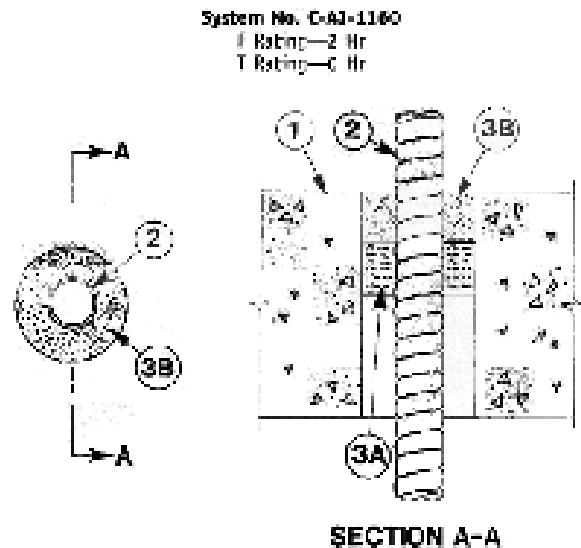

- Floor or Wall Assembly**—Min. 4-1/2 in. thick lightweight or normal weight (100 to 150 pcf) concrete. Will may also be constructed of any UL Classified Concrete Block\*. Size of circular through opening in floor or wall assembly to be 1/8 in. to 1-1/2 in. larger than diam. of flexible metal conduit (Item 2) installed in through opening. Max. diam. of opening is 6 in. See Concrete Block (CAC) category in the Fire Resistance Directory for names of manufacturers.
- Through Penetrating Product**\*—Max. 4 in. diam. (or smaller) pipe, or max. 3/4 in. diam. (or smaller) aluminum Flexible Metal Conduit. Max. one flexible metal conduit to be installed near center of circular through opening in floor or wall assembly. Flexible metal conduit to be rigidly supported on both sides of floor or wall assembly.  
 Alliance Cable Corp.
- Packing Material**—Max. 1 in. thickness of organic (polyimide silk) fiber Matul or mineral wool batt insulation. Insulation to be secured into 1 in. from top surface of floor or from both surfaces of wall.
- FILL Void or Cavity Material**\*—Gauze—Applied to fill the annular space around the flexible metal conduit. In floors, a min. 2 in. depth of fill material to be installed flush with top surface of floor. In walls, a min. 1 in. depth of fill material to be installed flush with wall surface on both sides of wall assembly.

Minnesota Mining & Mfg. Co.—TF 2700B

\*Bearing the UL Classification Mark  
 †Bearing the UL Listing Mark

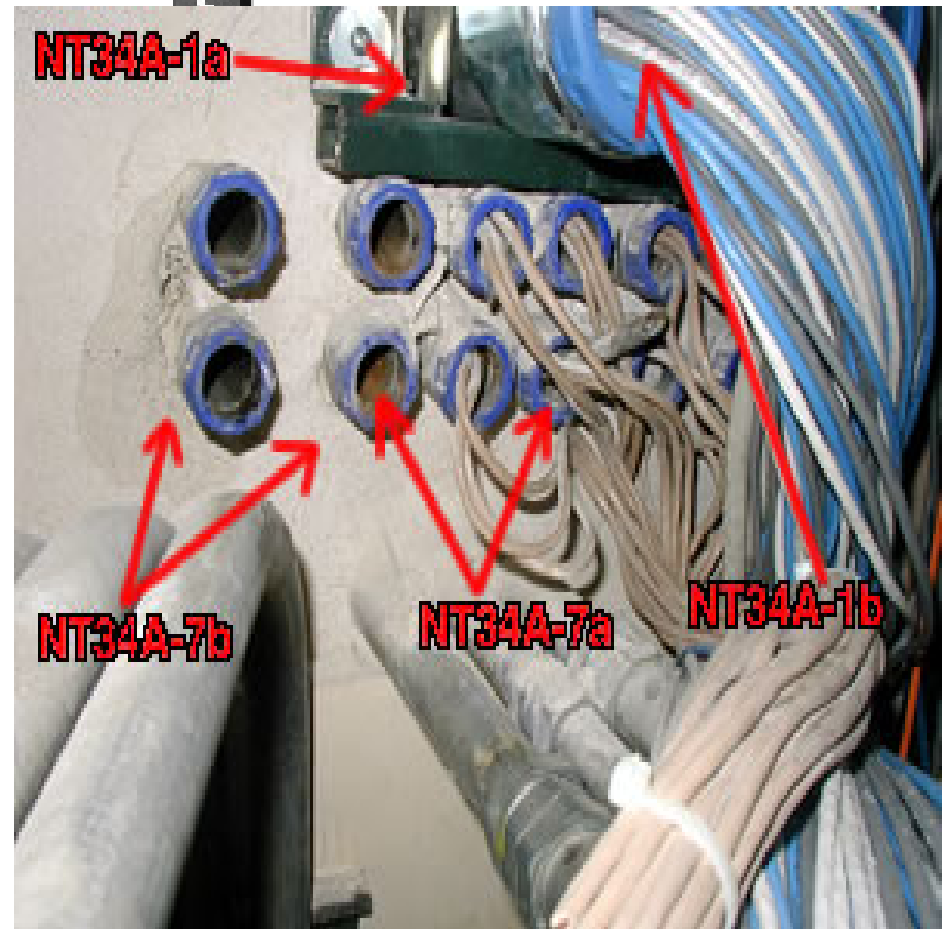

# Firestopping for Continuity

- **Firestop Products Become Firestop Systems --**
  - “A Specific field erected construction, consisting of an assemblage of materials to prevent the spread of fire through openings in fire rated walls and floors using ASTM E 814 / UL 1479 / **FM 4990**, ULC-S-115, UL 2079, **E-2307** as the test method...”
  - **Testing = Suitability statement for use of a firestop product in a specific system application**

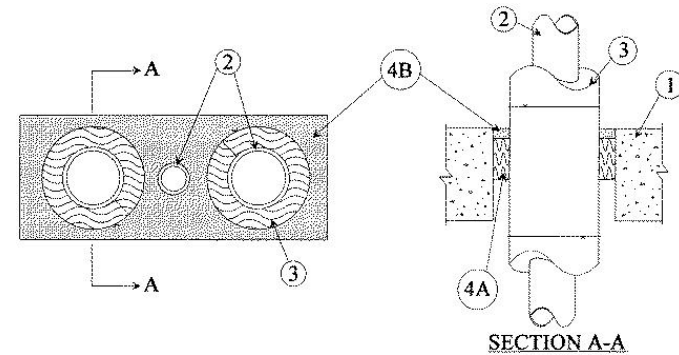

# Firestopping for Continuity

## Firestop Products

- **Sealants**
  - Silicone, Latex, Intumescent
- **Wrap Strips**
  - “Thick, Thin, Wide, Less Wide”
- **Putties**
- **Pillows**
- **Composite Sheets**
- **Bricks / Plugs**
- **Pre Fabricated Kits**
- **Mortar**
- **Spray Products**

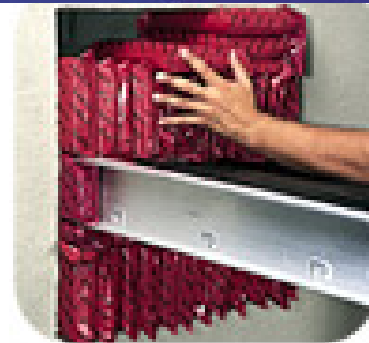
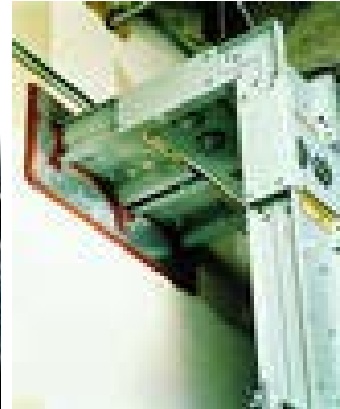



# Fire/Smoke Dampers & Firestops

- Dampers are UL 555, 555S Listed *Systems*
  - Installed to manufacturer's written instructions (Systems
    - Angles...no sealants)
- Firestop sealants – UL 1479 –
  - Improper hole sizing or poor installation...

**Consult the Damper  
Manufacturer & the  
Authority Having  
Jurisdiction**

Graphics - Greenheck



# Fire/Smoke Dampers Firestop Installation

- Combination Fire Smoke Dampers
- Multi-blade Fire Dampers
- Underfloor applications
- Max. size 72" W x 96" H
- SYSTEM...AHJ

- Greenheck Graphic



# Firestop Materials, Systems & Physical Properties

- **Serve Building Needs**
  - Smoke
  - Germs
  - Chemical Resistance – Cleaning?
  - Chemical, Biological, Radiation?
- **Product Types**
  - Intumescent, Latex, Silicone
  - Ablative
  - Endothermic



# D- Design

## SYSTEMS SELECTION

## SYSTEMS ANALYSIS

Who's Responsible, How to Choose???

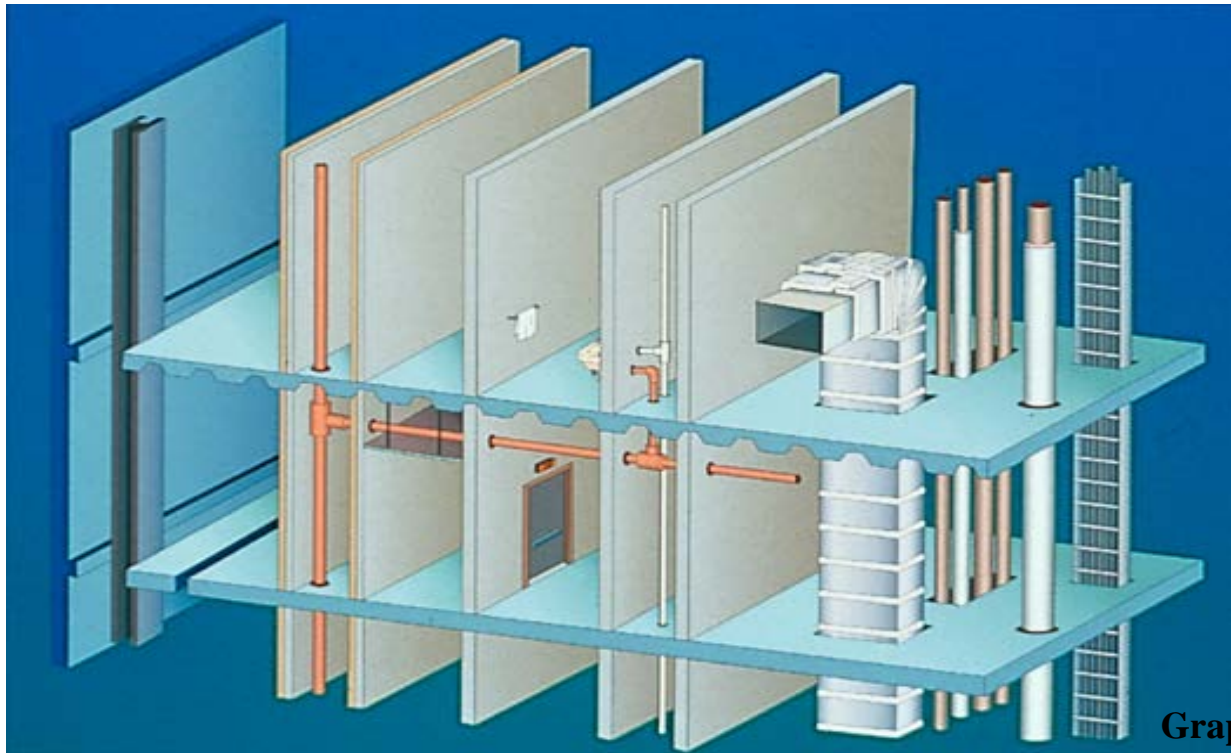

Graphics – STI

# Firestopping for Continuity

## Products become **SYSTEMS**

- After Installation...
- **‘Field Erected Construction...Tested to...’**
  - Standards - ASTM E814/UL 1479–UL 2079, ASTM E 1966, ASTM E 2307, ULC S-115, FM 4990
  - **F Rating - Flame**
  - T Rating – Temperature
  - H Rating – Hose
  - **L Rating – Smoke**
  - **W Rating – Water**



Graphics – 3M



# Products become Systems

## Hose Stream = Shock Test







1. FLOOR OR WALL ASSEMBLY :

- A. MINIMUM 4-1/2" THICK LIGHTWEIGHT OR NORMAL WEIGHT CONCRETE FLOOR.
- B. U.L. CLASSIFIED CONCRETE BLOCK WALL (MINIMUM 8" BLOCK).

2. PENETRATING ITEM TO BE ONE OF THE FOLLOWING :

- A. MAXIMUM 20" DIAMETER STEEL PIPE.
- B. MAXIMUM 6" DIAMETER COPPER PIPE.
- C. MAXIMUM 6" DIAMETER STEEL CONDUIT.
- D. MAXIMUM 4" DIAMETER EMT.

3. OPTIONAL : MAXIMUM 22" DIAMETER STEEL PIPE SLEEVE (SCHEDULE 10 OR HEAVIER).

4. MINIMUM 4" THICKNESS MINERAL WOOL (MIN. 4 PCF DENSITY) RECESSED 1/2" FROM TOP OF SLEEVE.

5. MINIMUM 1/2" DEPTH HLT1 FS-ONE FIRESTOP SEALANT.

6. A GENEROUS BEAD OF HLT1 FS-ONE FIRESTOP SEALANT AROUND OUTER PERIMETER OF STEEL SLEEVE.

NOTES : 1. MAXIMUM DIAMETER OF OPENING = 22".

2. ANNULAR SPACE = MINIMUM 0", MAXIMUM 1-1/2".





Fire Stop Technologies, Inc.



Fire Stop Technologies, Inc.

## Gypsum Wall assembly running up to concrete over metal deck

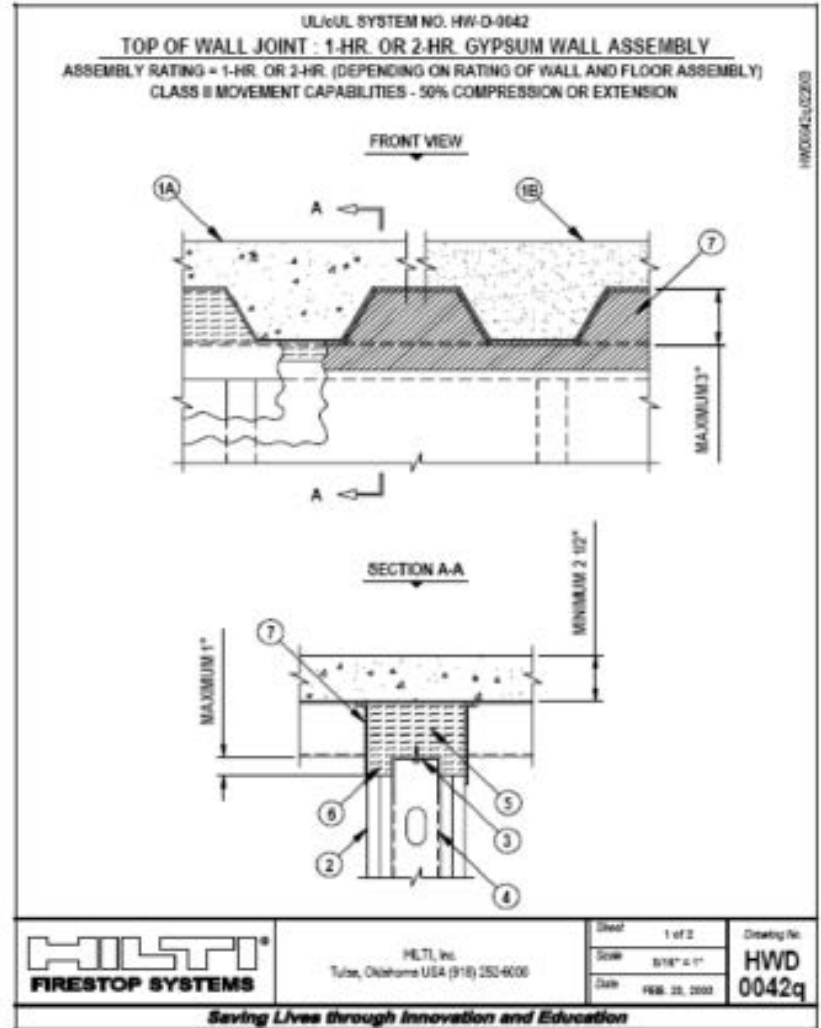

# How do Contractors Select Systems & Inspection Agencies Analyze?

- Wall or Floor Construction Type, Rating
  - Wall or Floor Thickness
  - Penetrating Item, Coverings
  - Size, Type, Thickness
  - Annular Space Sizes
  - Joint / Gap Sizes
  - Backing Materials
  - Fill Material(s)
- = Rated Firestop System

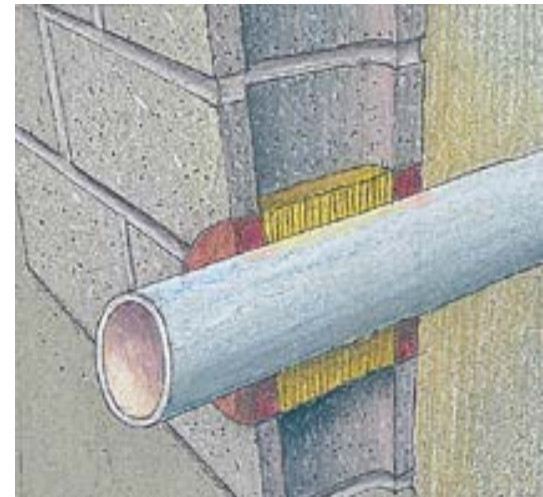

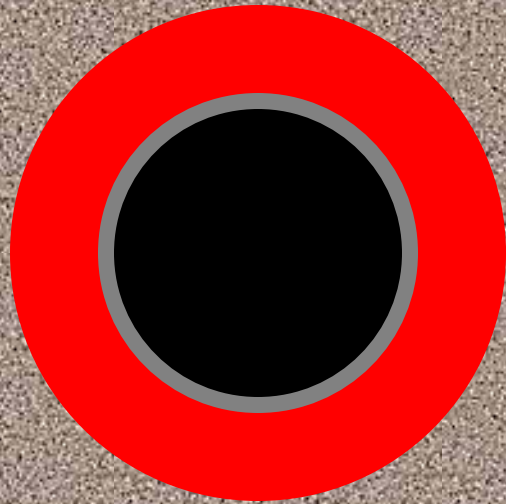

1. Centered

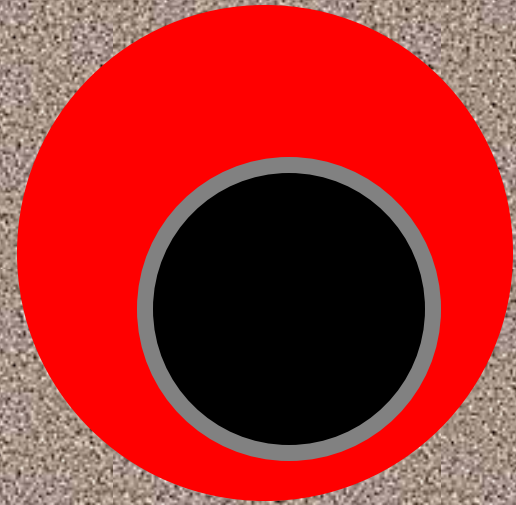

2. Off-Centered

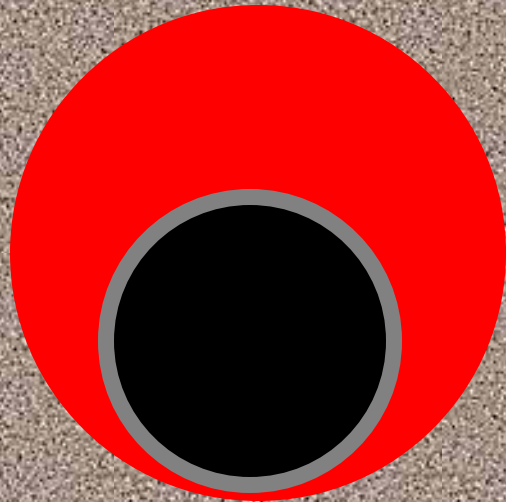

3. Point Contact

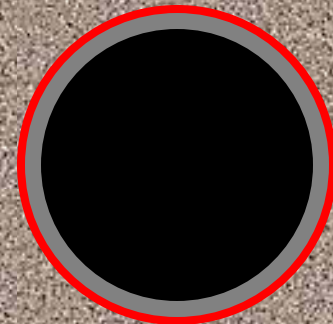

4. Continuous Point Contact

# Engineering Judgments/EFRRRA

- Field or other Variances to Tested and Listed Systems?
  - Impractical
  - No System Exists...anywhere.
- Why???
  - Lack of Planning
  - Unique Conditions



# Engineering Judgments/EFRRA

- Variances to Systems at Site ? – Now What...
  - **First Action in Process**
    - **Find another system** – Same Manufacturer
    - **Find another system** – Different Manufacturer
    - **If no system exists in either case....**
  - **Second Action –**
    - *Engineering Judgment* – “EJ”
    - *Equivalent Fire Resistance Rated Assembly* – “EFRRA”
  - *Based on engineering, IFC Protocol*

# Engineering Judgments/EFRRA

- Variances to Systems at Site ? – Now What...
  - **Third Action in Process**
    - **Expect language from manufacturer..**
      - ‘We believe this will pass the ASTM/UL Fire Tests’
    - **Submit for Approval through Channels**
    - **Document**

**IFC Guidelines for Evaluating Engineering Judgment  
Guidelines**

**‘Construction industry professionals, building officials, fire officials, firestop contractors and other stakeholders need appropriate guidelines for evaluating and using such judgments.’**

As such, IFC developed *Recommended IFC Guidelines for Evaluating FireStop Systems in Engineering Judgments*.

# **IFC EJ Guidelines - Engineering Judgments for firestop systems should:**

- 1. Not be used in lieu of tested systems when available;**
- 2. Be issued only by a firestop manufacturer's qualified technical personnel or in concert with the manufacturer by a knowledgeable registered Professional Engineer, Fire Protection Engineer, or an independent testing agency that provides listing services for firestop systems;**
- 3. Be based upon interpolation of previously tested firestop systems that are either sufficiently similar in nature or clearly bracket the conditions upon which the judgment is to be given. Additional knowledge and technical interpretations based upon accepted engineering principles, fire science and fire testing guidelines (e.g. ASTM E 2032 – Standard Guide for Extension of Data from Fire Endurance Tests, ULC Subject C263E – Criteria for Use in Extension of Data from Fire Endurance Tests, or ASTM E2750 – Standard Guide for Extensions of Data for Penetration Seals) may also be used as further support data;**



# **IFC EJ Guidelines**

**Engineering Judgments for firestop systems should:**

- 4. Be based upon full knowledge of the elements of the construction to be protected, the understanding of the probable behavior of that construction and the recommended firestop system protecting it were they to be subjected to the appropriate Firestop Standard Fire Test method for the rating indicated on the Engineering Judgment;**
- 5. Be limited only to specific conditions and configurations upon which the engineering judgment was rendered and should be based upon reasonable performance expectations for the recommended firestop system under those conditions;**
- 6. Be accepted only for a single, specific job and project location and should not be transferred to any other job or project location without thorough and appropriate review of all aspects of the next job or location's circumstances.**

# **IFC EJ Guidelines - Basic Presentation Requirements**

**Proper EJ's should:**

- 1. Be presented in appropriately descriptive written form with or without detail drawings where appropriate;**
- 2. Clearly indicate that the recommended firestop system is an EJ;**
- 3. Include clear directions for the installation of the recommended firestop system;**
- 4. Include dates of issue and authorization signature as well as the issuer's name, address and telephone number;**
- 5. Reference tested system(s) upon which design (EJ) is based on;**
- 6. Identify the job name, project location and firm EJ is issued to along with the non-standard conditions and rating supported by the EJ;**

# IFC EJ Presentation Guidelines – What’s Seen?

- 7. Have proper justification (i.e. UL, Intertek or other independent laboratory system(s) and or opinions);**
- 8. Provide complete descriptions of critical elements for the firestop configuration. These should include, but not be limited to the following:**

## **a. Basic, Common**

- Type(s) of assembly used or being penetrated;**
- Rating supported by the EJ.**

## **b. Through Penetrations**

- Penetrating item(s) (type, size, etc.);**
- Annular space requirements, (minimum, maximum, actual, nominal, etc.)**
- Opening size;**
- Firestop product(s) to be used, type and amount (thickness if applicable);**
- Accessory items(s) (i.e. anchors, backing material, etc.)**

## **c. Joints**

- Joint Width (installed width, nominal)**
- Movement Capability;**
- Movement Class (thermal wind sway, seismic);**
- Accessory item(s) (i.e. insulation type, thickness and compression, etc.)**

# **IFC EJ Presentation Guidelines – What’s Seen?**

**d•Duct Enclosure Systems – SEE [www.Firestop.org](http://www.Firestop.org)**

**e• Firestop System – annular space dimensions, floor/wall construction, design number, components, installed thickness.**

**f. Perimeter Fire Barrier Systems –**

- Type(s) of assembly used or being penetrated;**
- Hourly Rating required**
- Closest Listed System upon which the EJ is based**
- Joint Width**
- Static or Dynamic**
- Safing Insulation Types), thickness and compression, etc.**
- Five Basic Principles**
  - 1. Mechanical Attachment of the Spandrel Insulation**
  - 2. Protection of the Mullions**
  - 3. Compression Fitting and Orientation of the Safing Insulation**
  - 4. Installation of a Reinforcement Member(s), stiffener, at the safe-off area behind the spandrel insulation.**
  - 5. Firestop Coating, type, thickness,**

# IFC EJ Presentation Guidelines – What's Seen?

## *f• Continuity Head-of-Wall Joints*

- Joint Width, (installed width, nominal)*
- Movement Capability*
- Movement Class – (thermal, wind sway, seismic)*
- Accessory Item(s) (i.e. insulation type, thickness, compression, etc.)*

*IFC recommends that these guidelines be considered when evaluating whether any firestop system engineering judgment meets minimal requirements. Questions concerning the EJ request should be addressed to the initiator of the judgment.*

# Engineering Judgments/EFRRA

- ASTM E 2750 – Extension of Data from Penetration Firestop System Tests ... ASTM E814
  - **Standard for EJ/EFRRA's**
  - **Developed by ASTM Committee E-06**
  - **E-06 – Manufacturers, others**
  - **Not Joints...only Pens**

# ASTM E 2750 – Extension of Data

1.3 These principles are only applicable to temperature conditions represented by the standard time-temperature curve described in Test Method E814, for systems falling within the scope of Test Method E814. This test method is a fire-test Response standard.

# ASTM E 2750 – Extension of Data

1.12 This guide is used to measure and describe the response of materials, products, or assemblies to heat and flame under controlled conditions, but does not by itself incorporate all factors required for fire hazard or fire risk assessment of the materials, products or assemblies under actual fire conditions.



# ASTM E 2750 – Extension of Data

4.1 The methods and procedures set forth in this guide relate to the extension of the fire test results to firestop systems that have not been tested.

***FCIA NOTE: Is it a Firestop System if it's not tested or an Engineering Judgement?***

# ASTM E 2750 – Extension of Data

4.2 Users of this guide must have knowledge and understanding of the provisions of Test Method E119 and Test Method E814 including those pertaining to conditions of acceptance.

4.3 In order to apply some of the principles described in this guide, reference to the original fire test report will be necessary.

***FCIA Question: If Fire Test Report needed, can people other than the Manufacturer Write an EJ??***

# ASTM E 2750 – Extension of Data

4.4 In Test Method E814, the specimens are subjected to specific laboratory fire test exposure conditions. Differences between the tested assembly and the as-built assembly impact the fire-test-response characteristics. Substitution of different test conditions also impacts the fire-test-response characteristics.

# ASTM E 2750 – Extension of Data

4.5 The extension of data is valid only for the fire test exposure described in Test Method E814.

4.6 This guide shall not be used to extrapolate the fire resistance rating to a higher value.

# ASTM E 2750 – Extension of Data

## 4.7 *Limitations:*

4.7.1 The extension of fire resistance data is to be used only for changes to the tested specimen that fall *within normal and reasonable limits of accepted construction practices.*

4.7.2 Conclusions derived from using this guide are valid only if the identified change is the only change in the construction or properties of the components.

# ASTM E 2750 – Extension of Data

4.7.3 Evaluation of changes to the fire-resistive assembly in which the firestop is installed is governed by the Extension of Data principles in Guide E2032.

4.8 The statements in this guide are based on a single change to a system.

# ASTM E 2750 – Extension of Data

4.9 Extensions of data using this document shall be done by individuals possessing the following minimum qualifications and attributes:

4.9.1 an understanding of the Test Method E814 test procedure,

4.9.2 an understanding of the fire behavior of firestop Materials,

# ASTM E 2750 – Extension of Data

4.9.3 **knowledge of the elements of the construction to be protected,** and

4.9.4 **an understanding of the probable behavior of the underlying construction and the recommended firestop System** protecting it, were they to be subjected to testing in Accordance with Test Method E814.



# ASTM E 2750 – Extension of Data

4.10 The person performing evaluations based on tested or listed firestops shall be one of the following:

4.10.1 the firestop manufacturer's knowledgeable and Qualified technical personnel,

4.10.2 a registered professional engineer, or Fire Protection Engineer, knowledgeable in firestopping systems,

4.10.3 an independent testing agency or a listing agency, or

4.10.4 technical personnel with experience in firestopping.

# ASTM E 2750 – Extension of Data

5.3 Conclusions derived from using this guide indicate only whether or not a change in the application or design of the firestop system “reduces” the fire resistance rating.

5.4 The firestop system is limited to the maximum dimensions of the opening in the assembly that have been fire tested according to E814 or E119 under positive furnace pressure as specified in E814.

# ASTM E 2750 – Extension of Data

5.5 The firestop product(s) is limited to the product(s) fire tested.

5.6 *Angled Penetrations*—Where the penetrating item is indicated as a metallic pipe, conduit, tube, duct or cable, and the firestop system consists of a fill material (such as sealants, putty, or mortar) and a packing material, the penetrant may pass through the opening in the wall or floor assembly at an angle, provided the annular space is maintained on both sides of the wall or floor assembly. In all other cases, except where otherwise indicated in the system, the penetrating item shall penetrate the wall or floor assembly at a 90° angle.

# ASTM E 2750 – Extension of Data

## 6.1 *Concrete or Masonry Assemblies:*

6.1.1 Increase in thickness of the assembly will not decrease the fire resistance of the firestop. Exception: Where it is known

or suspected that locating a material further from the fire or on the unexposed side of the assembly will reduce the *F-rating*.

6.1.2 Firestop systems tested in concrete floor assemblies can be used in concrete or masonry wall assemblies providing that they are installed symmetrically on both sides of the wall.

6.1.2.1 Firestop systems need not be installed on both sides of the wall assembly if they are symmetrical and equidistant from both surfaces.

# ASTM E 2750 – Extension of Data

6.1.3 Firestop systems fire tested in wall assemblies cannot be installed in floor assemblies unless fire tested according to Test Method E814 as a floor assembly.

6.1.4 Firestop systems can be used in concrete or masonry assemblies of equal or lower fire resistance as long as the Firestop system tested design is not modified in relation to firestop thickness, bonding and support, and is not modified in relation to the assembly thickness.

# INSTALL FIRESTOP SYSTEM

## Firestop Sealant, MW installation to Tested and Listed System Limits = Firestop System



Pack

1



Apply Sealant

2



Tool/Smooth

3

Walls - BOTH SIDES

# Properly Tooled/Smoothed Firestop Sealants



# Sleeved Pipes





# Firestop Joint Systems Definition

---

- UL 2079, ASTM E 1966, ULC-S-115
  - “A joint system is a **specific construction** consisting of adjacent **wall and floor assemblies**, *and* the materials designed to prevent the spread of fire through a linear opening between the wall and / or floor assemblies”



# Firestop Perimeter Fire Containment Systems

- Firestop Perimeter Systems

**Definition – ASTM E 2307**

- “A Perimeter Fire Containment System is a **specific field erected construction** consisting of a floor with a fire resistance rating, and an exterior curtainwall with no hourly resistance rating, and the fill material installed between the floor and the curtain wall to prevent the vertical spread of fire in a building.”



# Firestop Perimeter Fire Containment Systems



Graphic – Intertek

# Proper Installation of Mineral Wool

- Compressed mineral wool must be inserted perpendicular to the joint to allow for movement between the slab and wall.

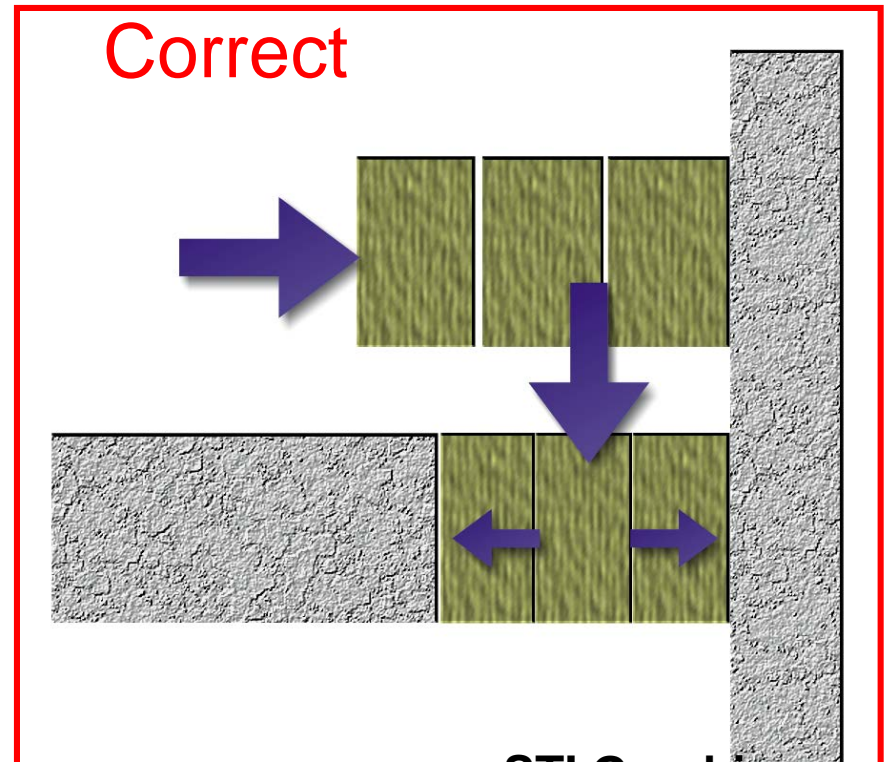
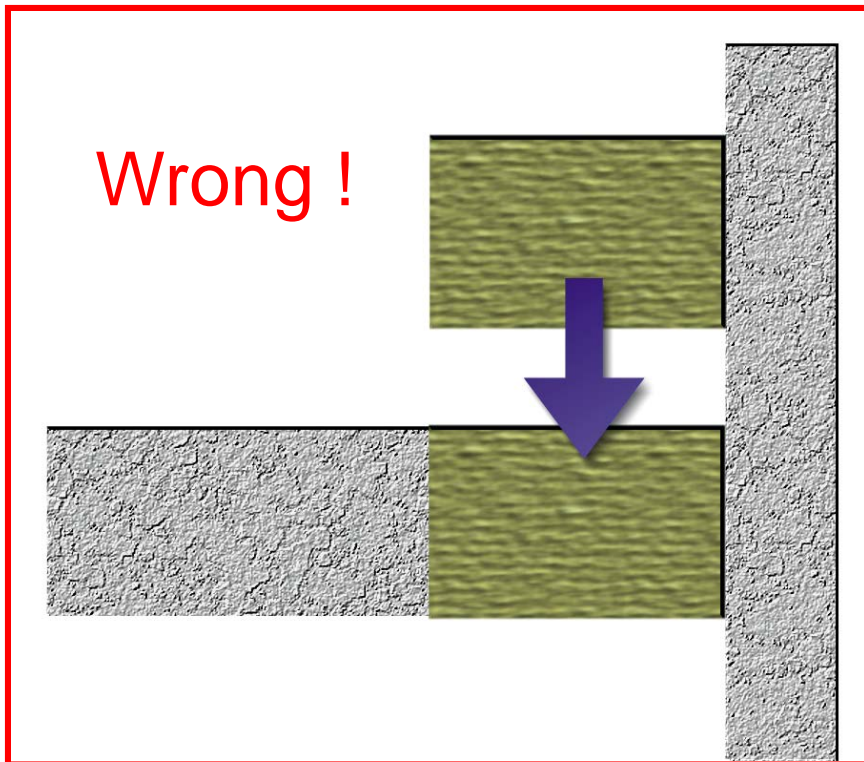



**STI Graphic**

# I- Installation

Who's Responsible, How to Choose???

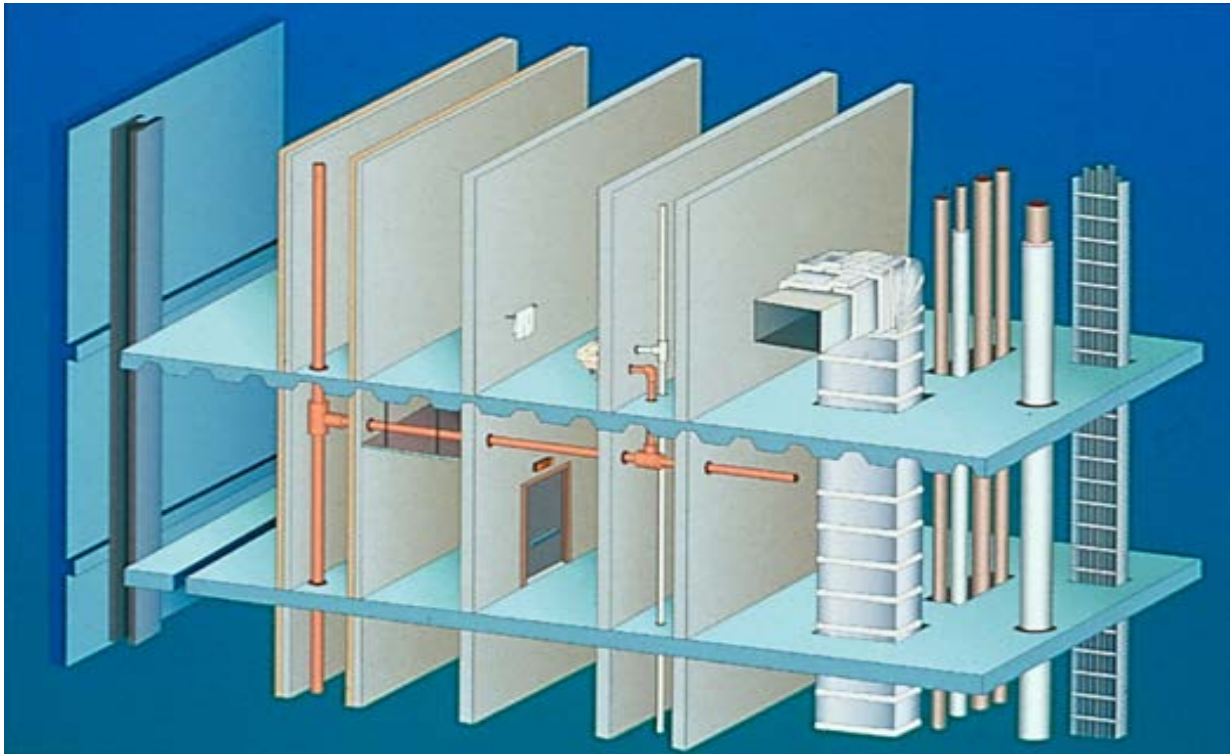

Graphics – STI

# Installation – Who?

- Firestopping wrong, missing
- Systems Documentation?
- As Built Documentation??

*Conclusion –*

*Without Single Firestopping Trade....*

*fire & life safety risks*



*Adler Photo*

# Why Contractor Qualifications?

- **Firestopping** Ratings - F, T, H, L W
- **Zero Tolerances?**
  - Annular Space Sizes, Gap Sizes
- **Product Properties**
  - Movement
  - Compatibility
  - Storage, Application, Curing Temps
- **SYSTEMS DOCUMENTATION**



# Firestop Contractor Qualifications

## FM & UL/ULC – 4 Components

1. Office Facility Quality Management System Audit
2. Field – Jobsite Audit
3. Employ a person
  - UL/FM Firestop Exam @ 80% or better
  - DRI if employed by Approved/Qualified Firm,
    - *Designated Responsible Individual (DRI)*
4. Annual Audit



# **1. Office Audit of Company Management System Manual**

- Controlled Management Processes
- Project Successful Proven Contractor
- Education, Training, Accountability

# 1. FM, UL/ULC Company Audit of Management System (MS)

- Employee Training & Education
- Systems Selection
- Communicate systems to Field
- Material Controls
- Systems installation “protocol”
- Labeling
- Record keeping - Variance Proce
- Non-Conformances
- Documentation
- Project closeout

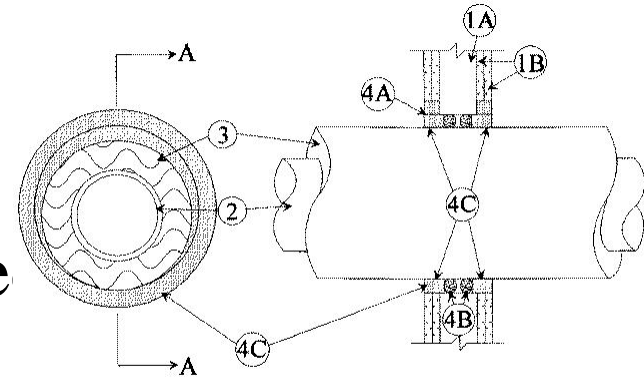

CONFIGURATION A

## 2. *Company MS Jobsite Audit* by **ULC, FM or UL**

- Verification of firestop systems Processes
- Verify Management System Works
- Verify Company “communication”
  - Office to field, field to office
- “Culture of Quality...”

»

Adler Photo



# 3. **DRI** – Company Appoints DRI if ....

- **Pass Rigorous Firestop Examination**
  - FCIA Firestop Manual of Practice
  - Firestop Systems Selection & Protocol
  - Management System Knowledge
- Keep CEU's – 6 FM, 10 UL, ea. 3 yrs.
- Retested every 3 years (FM Only)
- One DRI per Approved Contractor Location



# 4. Annual Audit

## FM 4991 UL / ULC

### Contractor Company Personnel

- Continued satisfactory performance
  - Quality Manual Implementation
- Documented - Archived record keeping
- Employee Training Documentation
- Jobsite Visit
- DRI CEU Verification
- **Find @ [www.fcia.org](http://www.fcia.org)**

# I – Inspection Systems Analysis

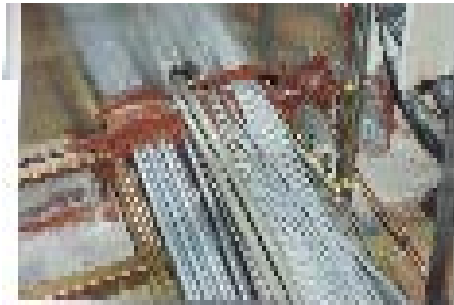

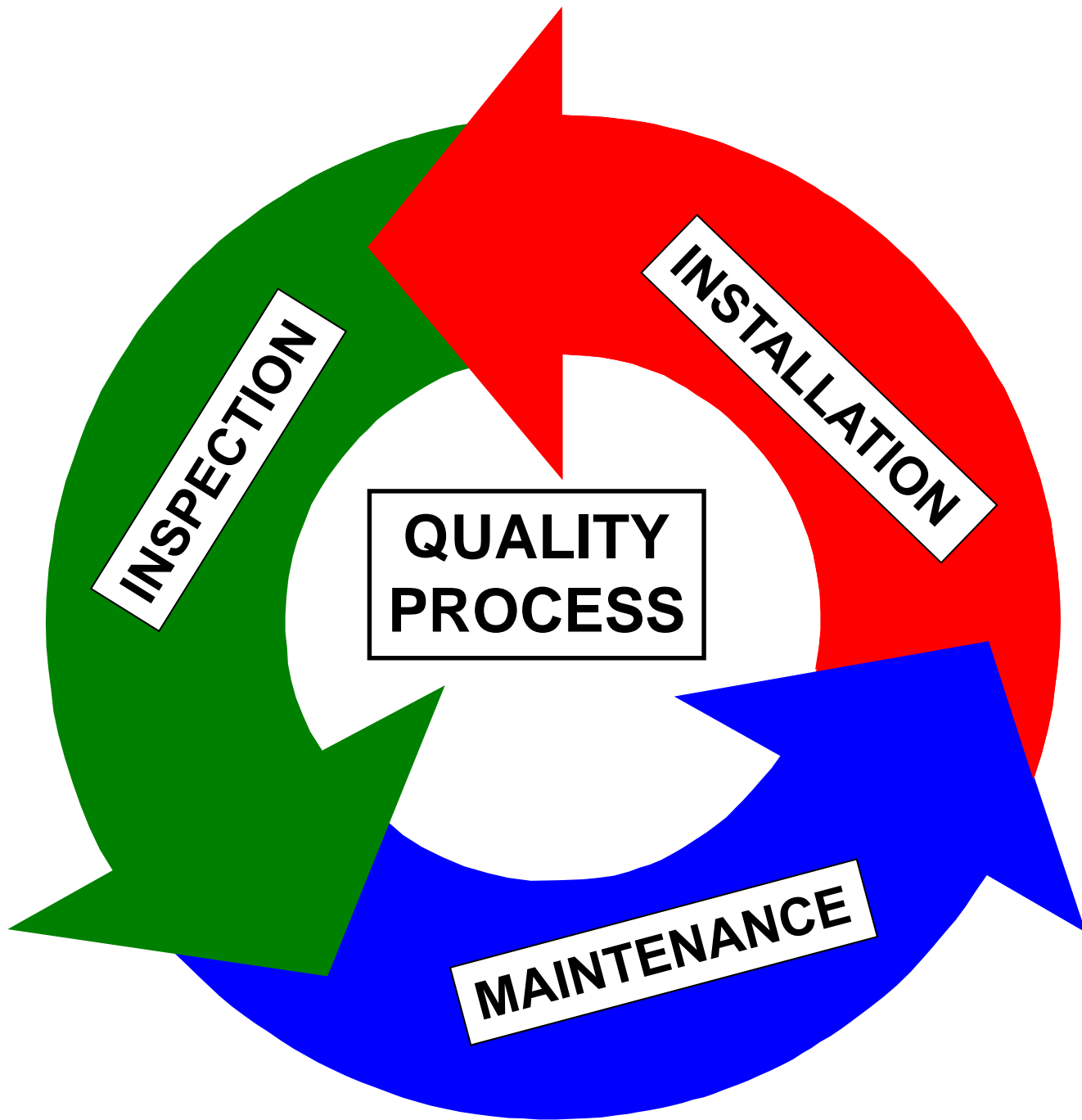

**INSPECTION**

**INSTALLATION**

**MAINTENANCE**

**QUALITY  
PROCESS**



# Firestop Installation & Inspection

- ASTM E 2174/ ASTM E 2393 –



# I – Inspection – Code Requirements

## Definitions

**[A] APPROVED AGENCY.** An **established and recognized agency** regularly engaged in conducting tests or furnishing inspection services, when such agency has been *approved*. [IBC 202. Definitions]

**[A] APPROVED.** Acceptable to the *building official* or authority having jurisdiction.

[IBC 202 Definitions]

# I – Inspection – Code Requirements

**SPECIAL INSPECTOR.** A qualified person *employed or retained by an approved agency* and *approved* by the *building official* as having the competence necessary to inspect a particular type of construction requiring *special inspection*. [IBC 202. Definitions]

# I – Inspection – Code Requirements

**1703.1.1 Independence.** An approved agency shall be objective, competent and independent from the contractor responsible for the work being inspected. The agency shall also disclose possible conflicts of interest so that objectivity can be confirmed. **[IBC 1703.1.2]**

**1703.1.2 Equipment.** An approved agency shall have adequate equipment to perform required tests. The equipment shall be periodically calibrated. **[IBC 1703.1.2]**

# I – Inspection – Code Requirements

**1704.2.1 Special inspector qualifications.** The special inspector shall provide written documentation to the building official demonstrating his or her competence and relevant experience or training. Experience or training shall be considered relevant when the documented experience or training is related in complexity to the same type of special inspection activities for projects of similar complexity and material qualities. These qualifications are in addition to qualifications specified in other sections of this code.

The registered design professional in responsible charge and engineers of record involved in the design of the project are permitted to act as the approved agency and their personnel are permitted to act as the special inspector for the work designed by them, provided they qualify as special inspectors.

# I – Inspection – Code Requirements

**1705.16.1 Penetration firestops.** Inspections of penetration firestop systems that are tested and listed in accordance with Sections 714.3.1.2 and 714.4.1.2 shall be conducted by an approved inspection agency in accordance with ASTM E 2174.

**1705.16.2 Fire-resistant joint systems.** Inspection of fire resistant joint systems that are tested and listed in accordance with Sections 715.3 and 715.4 shall be conducted by an approved inspection agency in accordance with ASTM E 2393.

# Firm and Individual Qualifications IAS AC 291

- Inspector Firm shall have at least one staff..
  - PASS UL or FM Firestop Exam
  - 1 year Quality Assurance
  - Or...*
  - PASS UL/FM Firestop Exam, *and* PE, FPE, Registered Architect, or
  - PASS UL/FM Firestop Exam, *and* Education by Certified Agency

# Inspection Methods

## ASTM E 2174 - ASTM E 2393

- During Construction
  - Random witness, Each Floor
    - **10%, each type** of Penetration Firestop, no less than one per floor
    - **5% of Total Lineal Feet** of Fire Resistance Rated Joint System, each type



Adler Photo



# Inspection Methods

## ASTM E 2174 - ASTM E 2393

- Post Construction - Destructive Testing
  - **Minimum 2%** , no less than 1, each type per 10,000 SF of floor area
  - **Minimum 1 / 500 LF** of Joint Area, mandatory
  - If 10% variance per firestop type
    - Inspection stops
    - Installer inspects, repairs
    - Inspector reinspects



# Inspection Methods

## ASTM E 2174 - ASTM E 2393

- Both Methods...
  - If 10% variance per firestop type
    - Inspection stops
    - Installer inspects, repairs
    - Inspector reinspects
  - Inspector Shall not Supervise Workers...
  - Inspect @ Firestop Installation Start

# Firestopping & Compartmentation for Safety

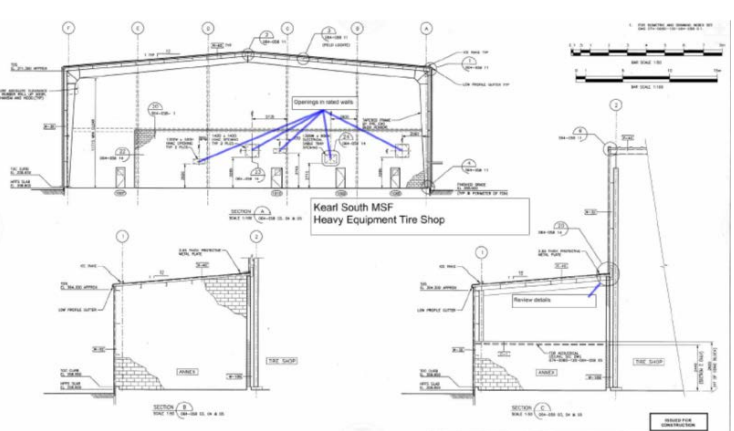
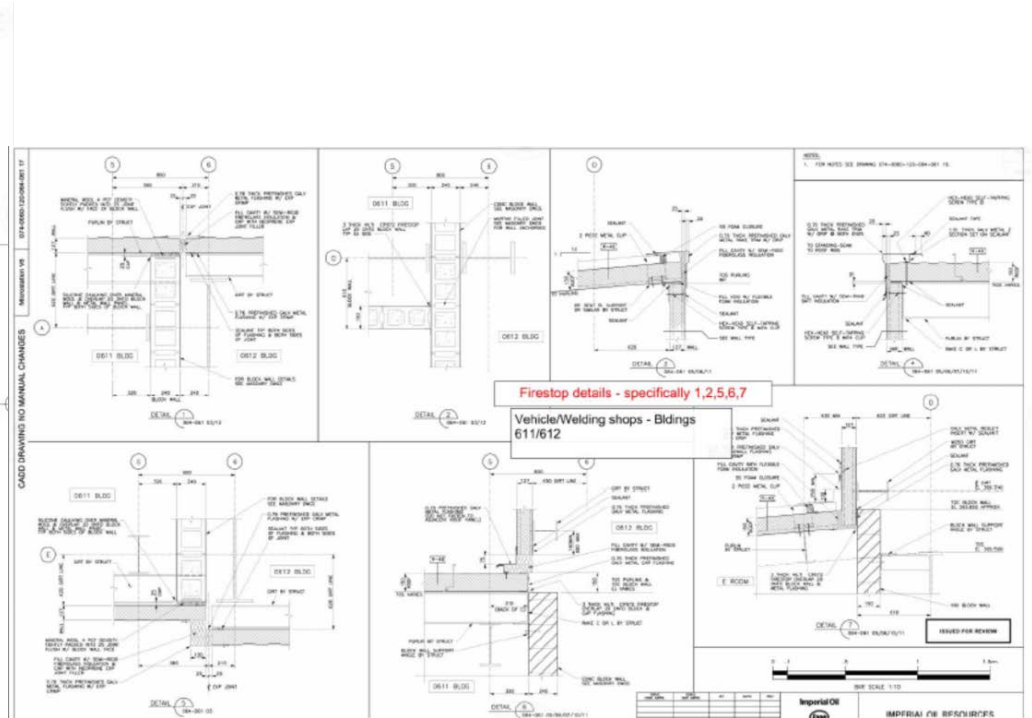
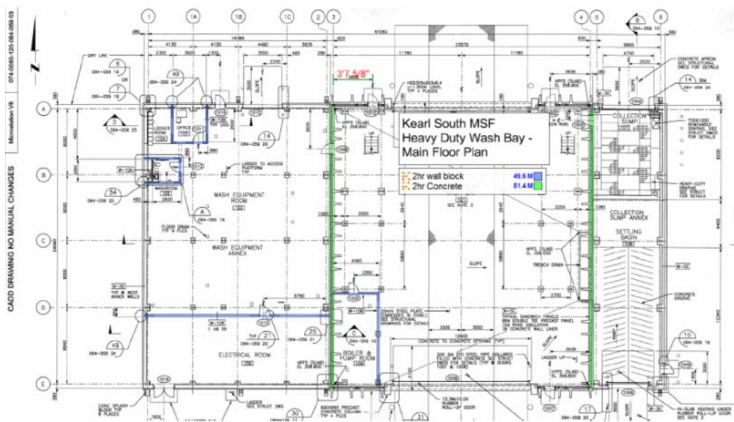

# M – Maintenance (& Management)

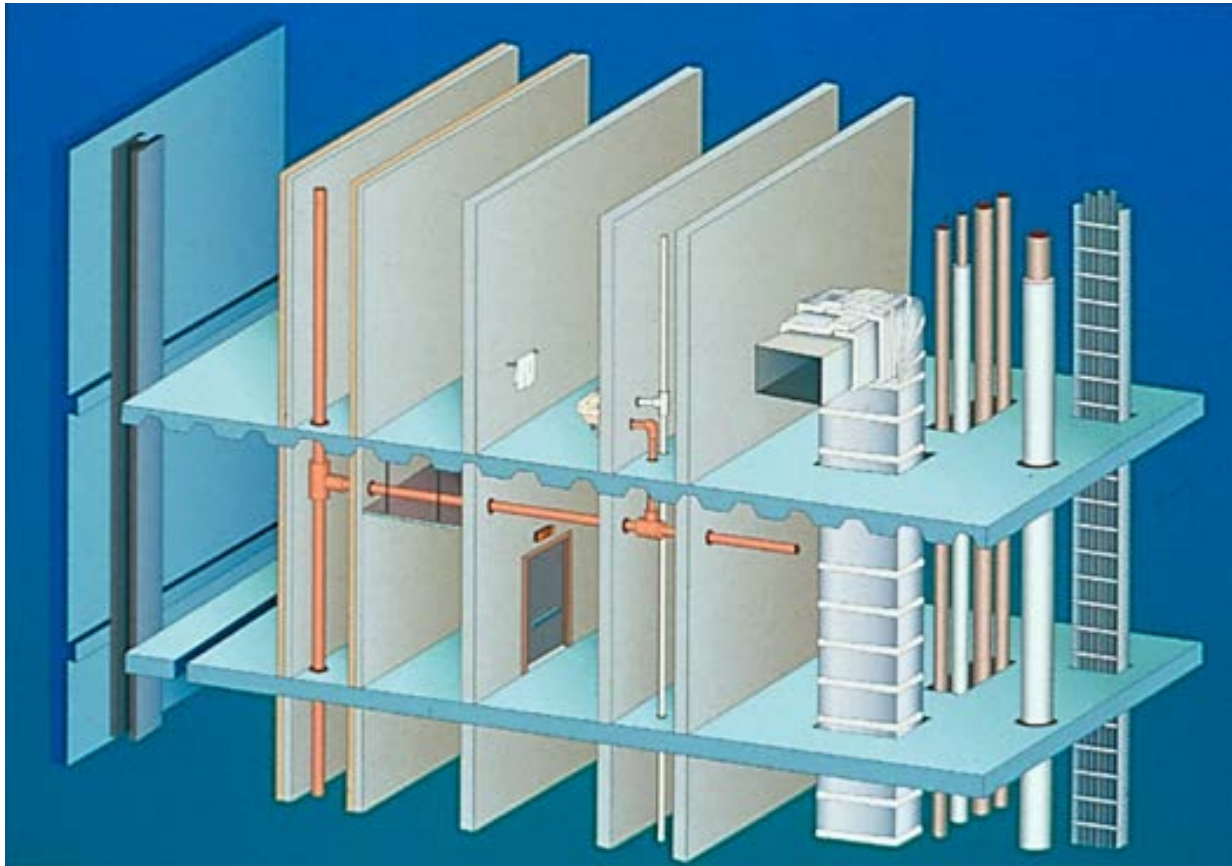

# International Fire Code Maintenance



## SECTION 703 FIRE-RESISTANCE-RATED CONSTRUCTION

**703.1 Maintenance.** The required fire resistance rating of fire-resistance rated construction (including walls, fire stops, shaft enclosures, partitions, smoke barriers, floors, fire resistive coatings and sprayed fire resistant materials applied to structural members and fire resistive joint systems) shall be maintained. Such elements shall be visually inspected by the owner annually and properly repaired, restored or replaced when damaged, altered, breached or penetrated.

**Openings** made therein for the passage of pipes, electrical conduit, wires, ducts, air transfer openings, **and holes** made for any reason shall be protected with approved methods capable of resisting the passage of smoke and fire.

# FCIA DIIM & Firestopping

Proper ***DCIIM*** Means Reliable Systems...

- **Properly *Designed*** - A/E - Consultant
  - Tested and Listed Systems, FCIA Member Mfr's., Compartments per IBC, NFPA Codes, SUBMITTALS....*Specified (CCS, CDT, RSW)*
- **Properly *Coordinated & Installed***
  - **FCIA Member, FM 4991, or UL *Qualified Contractors***
- **Properly *Inspected***
  - ASTM E 2174 & ASTM E 2393, by IAS *Qualified Inspectors at IAS AC 291 Accredited Inspection Firms*
- **Properly *Maintained & Managed*** –
  - FCIA Member, FM 4991, or UL Qualified, IAS Accredited Firms

# FCIA DIIM & Firestopping I & I - Inspection Webinar

- Free Subscription to Life Safety Digest
  - Business Card
- Info @ FCIA.org,
- Free Spec FCIA.org....

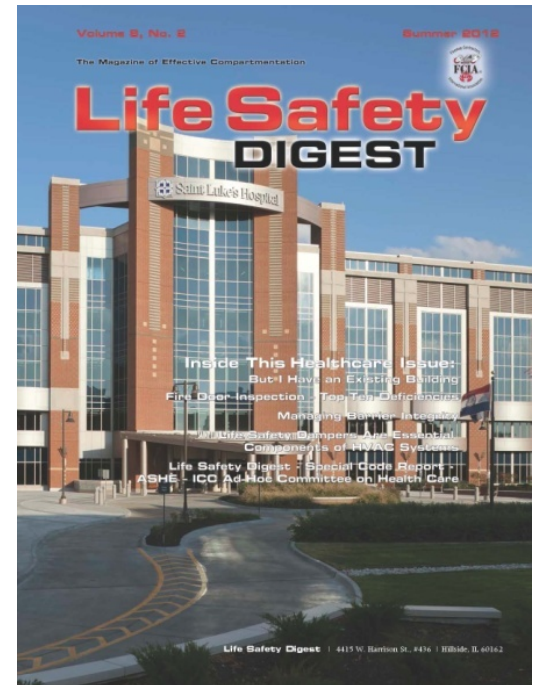



# Contacts

Firestop Contractors International Association

Hillside, IL – +1-708-202-1108 - office

Bill McHugh – bill @ fcia.org



# FCIA DIIM & Firestopping Chapter 1 – DIIM & Testing

18 February 2015

