

# FCIA's Webinar Series

## Inspection

08 June 2016





# Contacts

Firestop Contractors International Association

Hillside, IL – +1-708-202-1108 - office

Bill McHugh – bill @ fcia.org

# Learning Objectives

Upon completing this program, the participant should know how to:

1. Learn about ‘Why compartmentation and Firestopping’.
2. Recognize Perimeter Fire Containment, Penetration, Joint Product Design/Testing, **Installation & Inspection & Management** Standards & Code Requirements for Firestopping ... to become ... and stay, a ‘System’.
3. Understand Requirements for Firestopping for Safety in the US and Canada
4. Specification Section 07 84 00++ Highlights

# Outline

- FCIA – A Trade Association
  - Total Fire Protection & Effective Compartmentation
  - Codes, Testing, Products - Materials
  - Firestopping for Safety – A Quality Protocol
    - DIIM



# “DIIM”

- Firestopping for Safety – DIIM
  - Properly *Designed* and Specified Firestopping  
FCIA - 07-84-00 - Specification
  - *Tested and Listed Systems* - ASTM E 814 –  
ASTM E 1966, ASTM E2307, UL1479, UL2079,  
FM 4990, ULC-S-115
  - Professional *Installation* – FCIA Member, FM  
4991 Approved, UL/ULC Qualified Contractors
  - Properly *Inspected* - ASTM E 2174 / 2393  
Protocol by IAS AC 291 Accredited Agencies
  - *Maintained & Managed* - Annually - FCIA  
Members – NFPA 101, International Fire Code

# Firestop Contractors International Association

- FCIA – Worldwide Association
- Firestop Contractors, Manufacturers, Consultants, Reps, Distributors,
- Life Safety Digest
- FCIA Website Resources - FREE
- FCIA MOP on PDF FREE to Specifiers, Architects, Governmental Bldg./Fire Officials, worldwide..  
– [www.fcia.org](http://www.fcia.org)

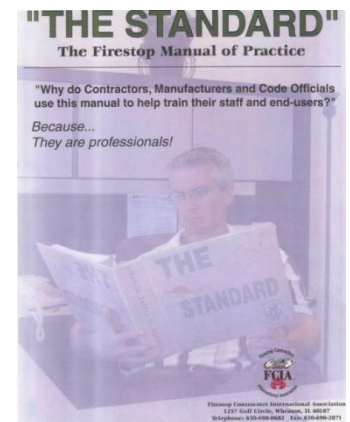
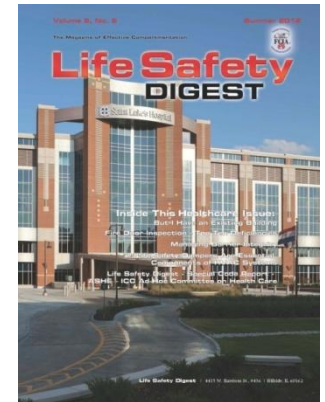

# “TOTAL FIRE PROTECTION”

- Effective Compartmentation
  - Fire Barriers, Fire Walls/Floors, Smoke Barriers
  - Firestopping, Fire Dampers, Swinging and Rolling Fire Doors, Fire Rated Glazing
- Detection & Alarm Systems
- Sprinkler Suppression Systems
- Education & Egress—
  - Building Owners & Managers, Building Occupants and Firefighters



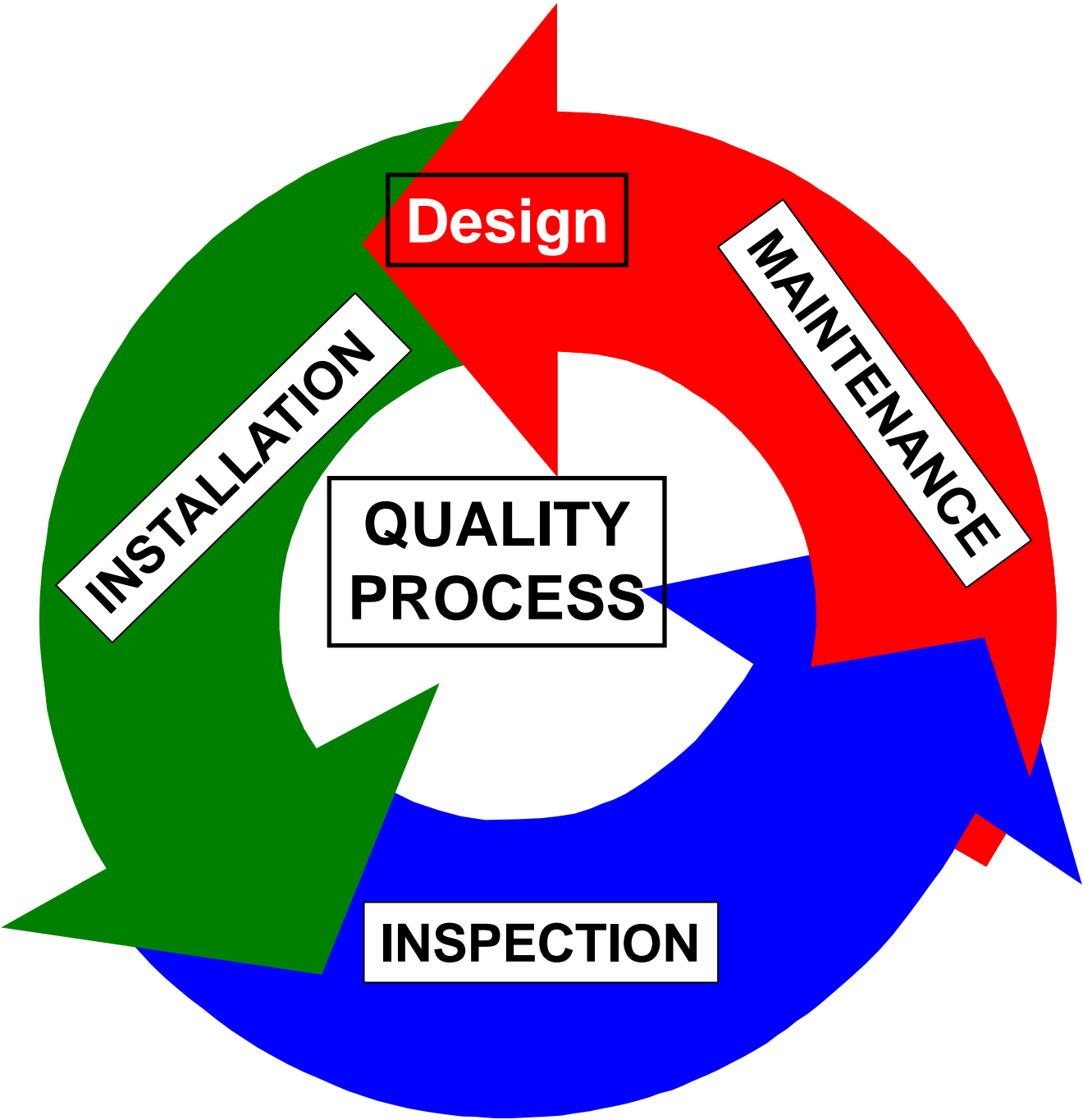

**Design**

**MAINTENANCE**

**QUALITY  
PROCESS**

**INSPECTION**

**INSTALLATION**



# “DIIM”

- Firestopping for Safety – DCIIMM
  - Properly *Designed* and Specified Firestopping  
FCIA - 07-84-00 - Specification
  - *Tested and Listed Systems* - ASTM E814-E1966,  
UL1479-UL2079, ULC-S-115, ASTM E2307
  - *Coordinate* – Breaches, Penetrating Items
  - Professional *Installation* – FCIA Member,  
FM 4991 Approved, UL Qualified Contractors
  - Properly *Inspected* - ASTM E 2174 / 2393  
Protocol by IAS AC 291 Inspection Agencies
  - *Maintained & Managed* - Annually - NFPA 101,  
International Fire Code, UAE Fire & Life Safety

# Building & Fire Code Requirements

- NFPA 5000 – 101- Chapter 8
- National Building & Fire Code of Canada
- UAE Fire and Life Safety Code – Chapter 21
- International Codes –
  - New and Existing Buildings
    - International Building Code – Chapter 7
    - International Fire Code – Chapter 7
- ***Minimum requirements - Construction & Maintenance***



# Building & Fire Code Requirements

- Compartmentation Codes – US –
  - **Fire Resistance** – Time, in minutes or hours that materials or assemblies have withstood a fire exposure as...
    - **Determined by tests,**
    - **Methods based on tests, or**
    - **This code ....**
  - NFPA, Ch 8. **ICC adds... “*Systems*”**

# Fire Resistance

**703.2 Fire-resistance ratings.** The *fire-resistance rating* of building elements, components or assemblies shall be determined in accordance with the test procedures set forth in ASTM E 119 or UL 263 or in accordance with Section 703.3.

The *fire-resistance rating* of penetrations and fire-resistant joint systems shall be determined in accordance Sections 714 and 715, respectively.

[UL Guide Information]

# Fire Resistance

**703.3 Methods for determining fire resistance.** The application of any of the methods listed in this section shall be based on the fire exposure and acceptance criteria specified in ASTM E 119 or UL 263. The required *fire resistance* of a building element, component or assembly shall be permitted to be established by any of the following methods or procedures:

1. Fire-resistance designs documented in approved sources.
2. Prescriptive designs of fire-resistance-rated building elements, components or assemblies as prescribed in Section 721.
3. Calculations in accordance with Section 722.
4. Engineering analysis based on a comparison of building element, component or assemblies designs having *fire-resistance ratings* as determined by the test procedures set forth in ASTM E 119 or UL 263.
5. Alternative protection methods as allowed by Section 104.11.
6. Fire-resistance designs certified by an approved agency.

[IBC 2015, 703.3]

# Fire Resistance

## 705. Exterior Walls

**705.9 Joints.** Joints made in or between *exterior walls* required by this section to have a *fire-resistance rating* shall comply with Section 715.

**Exception:** Joints in *exterior walls* that are permitted to have unprotected openings.

**705.9.1 Voids.** The void created at the intersection of a floor/ceiling assembly and an exterior curtain wall assembly shall be protected in accordance with Section 715.4.

[IBC 2015, 703.3]

# Fire Resistance

## 706 Fire Walls

**706.5 Horizontal continuity.** *Fire walls* shall be continuous from *exterior wall* to *exterior wall* and shall extend not less than 18 inches (457 mm) beyond the exterior surface of *exterior walls*.

### **Exceptions:**

1. *Fire walls* shall be permitted to terminate at the interior surface of combustible exterior sheathing or siding provided the *exterior wall* has a *fire-resistance rating* of not less than 1 hour for a horizontal distance of not less than 4 feet (1220 mm) on both sides of the *fire wall*. Openings within such *exterior walls* shall be protected by opening protectives having a *fire protection rating* of not less than 3/4 hour.
2. *Fire walls* shall be permitted to terminate at the interior surface of noncombustible exterior sheathing, exterior siding or other noncombustible exterior finishes provided the sheathing, siding or other exterior noncombustible finish extends a horizontal distance of not less than 4 feet (1220 mm) on both sides of the *fire wall*.
3. *Fire walls* shall be permitted to terminate at the interior surface of noncombustible exterior sheathing where the building on each side of the *fire wall* is protected by an *automatic sprinkler system* installed in accordance with Section 903.3.1.1 or 903.3.1.2.

[IBC 2015, 703.3]

# Fire Resistance

## 706 Fire Walls

**706.5 Horizontal continuity.** *Fire walls* shall be continuous from *exterior wall* to *exterior wall* and shall extend not less than 18 inches (457 mm) beyond the exterior surface of *exterior walls*.

### **Exceptions:**

1. *Fire walls* shall be permitted to terminate at the interior surface of combustible exterior sheathing or siding provided the *exterior wall* has a *fire-resistance rating* of not less than 1 hour for a horizontal distance of not less than 4 feet (1220 mm) on both sides of the *fire wall*. Openings within such *exterior walls* shall be protected by opening protectives having a *fire protection rating* of not less than 3/4 hour.
2. *Fire walls* shall be permitted to terminate at the interior surface of noncombustible exterior sheathing, exterior siding or other noncombustible exterior finishes provided the sheathing, siding or other exterior noncombustible finish extends a horizontal distance of not less than 4 feet (1220 mm) on both sides of the *fire wall*.
3. *Fire walls* shall be permitted to terminate at the interior surface of noncombustible exterior sheathing where the building on each side of the *fire wall* is protected by an *automatic sprinkler system* installed in accordance with Section 903.3.1.1 or 903.3.1.2.

[IBC 2015, 703.3]



# Fire Resistance

## 706 Fire Walls

**706.6 Vertical continuity.** *Fire walls* shall extend from the foundation to a termination point not less than 30 inches (762 mm) above both adjacent roofs.

### **Exceptions:**

1. Stepped buildings in accordance with Section 706.6.1.
2. Two-hour fire-resistance-rated walls shall be permitted to terminate at the underside of the roof sheathing, deck or slab, provided:
  - 2.1. The lower roof assembly within 4 feet (1220 mm) of the wall has not less than a 1-hour *fire-resistance rating* and the entire length and span of supporting elements for the rated roof assembly has a *fire-resistance rating* of not less than 1 hour.
  - 2.2. Openings in the roof shall not be located within 4 feet (1220 mm) of the *fire wall*.
  - 2.3. Each building shall be provided with not less than a Class B roof covering.
3. Walls shall be permitted to terminate at the underside of noncombustible roof sheathing, deck or slabs where both buildings are provided with not less than a Class B roof covering. Openings in the roof shall not be located within 4 feet (1220 mm) of the *fire wall*. ....  
MORE EXCEPTIONS....

**[IBC 2015 706.6]**

# Fire Resistance

706 Fire Walls

**706.9 Penetrations.** Penetrations of *fire walls* shall comply with Section 714.

**706.10 Joints.** Joints made in or between *fire walls* shall comply with Section 715.

**[IBC 2015 706.9]**

# Fire Resistance

## 707 Fire Barriers

**707.5 Continuity.** *Fire barriers* shall extend from the top of the foundation or floor/ceiling assembly below to the underside of the floor or roof sheathing, slab or deck above and shall be securely attached thereto. Such *fire barriers* shall be continuous through concealed space, such as the space above a suspended ceiling. Joints and voids at intersections shall comply with Sections 707.8 and 707.9

**707.7 Penetrations.** Penetrations of *fire barriers* shall comply with Section 714.

**707.7.1 Prohibited penetrations.** Penetrations into enclosures for *exit access stairways* and *ramps, interior exit stairways* and *ramps*, and *exit passageways* shall be allowed only where permitted by Sections 1019, 1023.5 and 1024.6, respectively.

**[IBC 2015 707.7]**

# Fire Resistance

## 707 Fire Barriers

**707.8 Joints.** Joints made in or between *fire barriers*, and joints made at the intersection of *fire barriers* with underside of a fire-resistance-rated floor or roof sheathing, slab or deck above, and the exterior vertical wall intersection shall comply with Section 715.

**707.9 Voids at intersections.** The voids created at the intersection of a *fire barrier* and a non fire-resistance-rated roof assembly or a non fire-resistance-rated exterior wall assembly shall be filled. An approved material or system shall be used to fill the void, and shall be securely installed in or on the intersection for its entire length so as not to dislodge, loosen or otherwise impair its ability to accommodate expected building movements and to retard the passage of fire and hot gases.

**[IBC 2015 707]**

# Fire Resistance

## 708 Fire Partitions

**708.4 Continuity.** Fire partitions shall extend from the top of the foundation or floor/ceiling assembly below to the underside of the floor or roof sheathing, slab or deck above or to the fire-resistance-rated floor/ceiling or roof/ceiling assembly above, and shall be securely attached thereto. In combustible construction where the *fire partitions* are not required to be continuous to the sheathing, deck or slab, the space between the ceiling and the sheathing, deck or slab above shall be fireblocked or draftstopped in accordance with Sections 718.2 and 718.3 at the partition line. The supporting construction shall be protected to afford the required *fire-resistance rating* of the wall supported, except for walls separating tenant spaces in *covered and open mall buildings*, walls separating *dwelling units*, walls separating *sleeping units* and *corridor walls*, in buildings of Type IIB, IIIB and VB construction.

**[IBC 708, Fire Partitions]**

# Fire Resistance

## 708 Fire Partitions

**Exception:** *Smoke-barrier* walls are not required in interstitial spaces where such spaces are designed and constructed with ceilings or *exterior walls* that provide resistance to the passage of fire and smoke equivalent to that provided by the *smoke-barrier* walls.

**709.4.1 Smoke-barrier walls separating smoke compartments.** *Smoke-barrier* walls used to separate smoke compartments shall form an effective membrane continuous from outside wall to outside wall.

**709.4.2 Smoke-barrier walls enclosing areas of refuge or elevator lobbies.** *Smoke-barrier* walls used to enclose areas of refuge in accordance with Section 1009.6.4, or to enclose elevator lobbies in accordance with Section 405.4.3, 3007.6.2, or 3008.6.2, shall form an effective membrane enclosure that terminates at a *fire barrier* wall having a level of *fire protection rating* not less than 1 hour, another *smoke barrier* wall or an outside wall. A smoke and draft control door assembly as specified in Section 716.5.3.1 shall not be required at each elevator hoistway door opening or at each exit doorway between an area of refuge and the exit enclosure.

**708.7 Penetrations.** Penetrations of *fire partitions* shall comply with Section 714.

**708.8 Joints.** Joints made in or between *fire partitions* shall comply with Section 715.

[IBC 708, Fire Partitions]

# Fire Resistance

## 709 Smoke Barriers

**709.3 Fire-resistance rating.** A 1-hour *fire-resistance rating* is required for *smoke barriers*.

**Exception:** *Smoke barriers* constructed of minimum 0.10-inch-thick (2.5 mm) steel in Group I-3 buildings.

**709.4 Continuity.** *Smoke barriers* shall form an effective membrane continuous from the top of the foundation or floor/ceiling assembly below to the underside of the floor or roof sheathing, deck or slab above, including continuity through concealed spaces, such as those found above suspended ceilings, and interstitial structural and mechanical spaces. The supporting construction shall be protected to afford the required *fire-resistance rating* of the wall or floor supported in buildings of other than Type IIB, IIIB or VB construction. *Smoke barrier* walls used to separate smoke compartments shall comply with Section 709.4.1. *Smoke-barrier* walls used to enclose areas of refuge in accordance with Section 1009.6.4 or to enclose elevator lobbies in accordance with Section 405.4.3, 3007.6.2, or 3008.6.2 shall comply with Section 709.4.2.

**709.6 Penetrations.** Penetrations of *smoke barriers* shall comply with Section 714.

**709.7 Joints.** Joints made in or between *smoke barriers* shall comply with Section 715.

**[IBC 709, Smoke Barriers]**

# Fire Resistance

## 710 Smoke Partitions

**710.3 Fire-resistance rating.** Unless required elsewhere in the code, smoke partitions are not required to have a *fireresistance rating*.

**710.4 Continuity.** Smoke partitions shall extend from the top of the foundation or floor below to the underside of the floor or roof sheathing, deck or slab above or to the underside of the ceiling above where the ceiling membrane is constructed to limit the transfer of smoke.

**710.6 Penetrations.** The space around penetrating items shall be filled with an *approved* material to limit the free passage of smoke.

**710.7 Joints.** Joints shall be filled with an *approved* material to limit the free passage of smoke.

**[IBC 710, Smoke Partitions]**



# Fire Resistance

## 711 Horizontal Assemblies

**711.2.4 Fire-resistance rating.** The *fire-resistance rating* of *horizontal assemblies* shall comply with Sections 711.2.4.1 through 711.2.4.6 but shall be not less than that required by the building type of construction.

**711.2.4.4 Separating smoke compartments.** Where the *horizontal assembly* is required to be a *smoke barrier*, the assembly shall comply with Section 709.

**[IBC 711, Horizontal Assemblies]**

# Fire Resistance

## 712 Vertical Openings

**712.1 General.** Each vertical opening shall comply in accordance with one of the protection methods in Sections 712.1.1 through 712.1.16.

**712.1.4 Penetrations.** Penetrations, concealed and unconcealed, shall be permitted where protected in accordance with Section 714.

**712.1.5 Joints.** Joints shall be permitted where complying with Section 712.1.5.1 or 712.1.5.2, as applicable.

**[IBC 712, Vertical Openings]**

# Fire Resistance

## 712 Vertical Openings

**712.1.5.1 Joints in or between horizontal assemblies.** Joints made in or between *horizontal assemblies* shall comply with Section 715. The void created at the intersection of a floor/ceiling assembly and an exterior curtain wall assembly shall be permitted where protected in accordance with Section 715.4.

**712.1.5.2 Joints in or between nonfire-resistance rated floor assemblies.** Joints in or between floor assemblies without a required *fire-resistance rating* shall be permitted where they comply with one of the following:

1. The joint shall be concealed within the cavity of a wall.
2. The joint shall be located above a ceiling.
3. The joint shall be sealed, treated or covered with an *approved* material or system to resist the free passage of flame and the products of combustion.

**Exception:** Joints meeting one of the exceptions listed in Section 715.1.

**[IBC 712, Vertical Openings]**

# Building & Fire Code Requirements

- Compartmentation Codes – US –
  - *Fire Resistance Continuity*
  - *Breaches - Openings & Penetrations*
  - *Robustness*

# Building & Fire Code Requirements

- Compartmentation Codes – US –
  - *Ch. 8 – NFPA – ASTM E 119, UL 263, NFPA 220*
  - **Ch. 7 – IBC - Fire Barrier** – Hourly Rated – IBC
  - **Ch. 7 IBC - Fire Wall** – Fire rating, structural independence
  - **Ch. 8 NFPA – NFPA 221 – High Challenge Fire Walls**
  - IBC – **Fire Partition** – Rated, not continuous.

# Building & Fire Code Requirements

- Fire Barriers
  - Fire Area Separations
  - Mixed Use Occupancies
  - Incidental Uses
  - Hazardous Area Separations
  - Exit Enclosures
  - Shaft enclosures
  - Horizontal Exits
  - Corridor Walls - NFPA

# Building & Fire Code Requirements

- Smoke Barriers
  - Healthcare
  - Other Occupancies
- IBC – Quantified L Rating for Firestops
- NFPA 101 - no quantified L Rating for Firestops

# Building & Fire Code Requirements

- **Compartmentation Codes – Breaches & Smoke**
  - **Smoke Barrier – Firestopping for Continuity**
    - IBC – Hourly Rated, “L” Rating
      - <5cfm/sf (IBC 2006)
      - < 50 cfm, 100sf of Wall Area (IBC 2009)
    - **NFPA – ... ‘restricting the passage of smoke’ ...**  
**no quantified “L” Rating ... YET**
      - Continuous, Barrier to Barrier, ... through concealed spaces,
      - Not always fire resistance rated.
  - **Smoke Partition**
    - IBC – Continuous barrier, not rated...’retard’.
    - NFPA – Continuous membrane that is designed to form a barrier to *limit the transfer of smoke*....



# Building & Fire Code Requirements

- Compartmentation Codes – US –
  - *Exterior Walls*
  - *Fire Walls*
  - *Fire Barriers*
  - *Fire Partitions (Not NFPA)*
  - *Smoke Barriers*
  - *Smoke Partitions*

# Building & Fire Code Requirements

- *Continuous Fire Resistance*
  - **Walls / Horizontal Assemblies – Continuity**
    - Products Become Firestop Systems
    - Breaches in Fire Resistance for:
      - Penetrations
      - Joints – Head /Bottom of Wall – Perimeter Joints
      - Fire & Smoke Damper Duct Systems
      - Fire Doors and Hardware Systems
        - » Rolling & Swinging
      - Fire Rated Glazing

# Building & Fire Code Requirements

- *Chemical, Biological, Radiation, Explosion, etc.*
  - **Standards?**
    - **R - Nuclear Power Plant Standards**
    - **E – Blast Strength? Check with manufacturer – 2psf**
    - **C – Which Chemicals? Check with manufacturer**
    - **B – Which Agents? Check with manufacturer**
    - **G – Germ – Check with manufacturer & industrial hygeinist**
  - **Due Diligence – Not Code Requirements, but...**

# Fire Resistance Continuity All Occupancies

- Effective Compartmentation
  - Education
  - Office
  - Mercantile
  - Multi Family Residential
  - Industrial – Insurance influences
  - Institutional – Healthcare

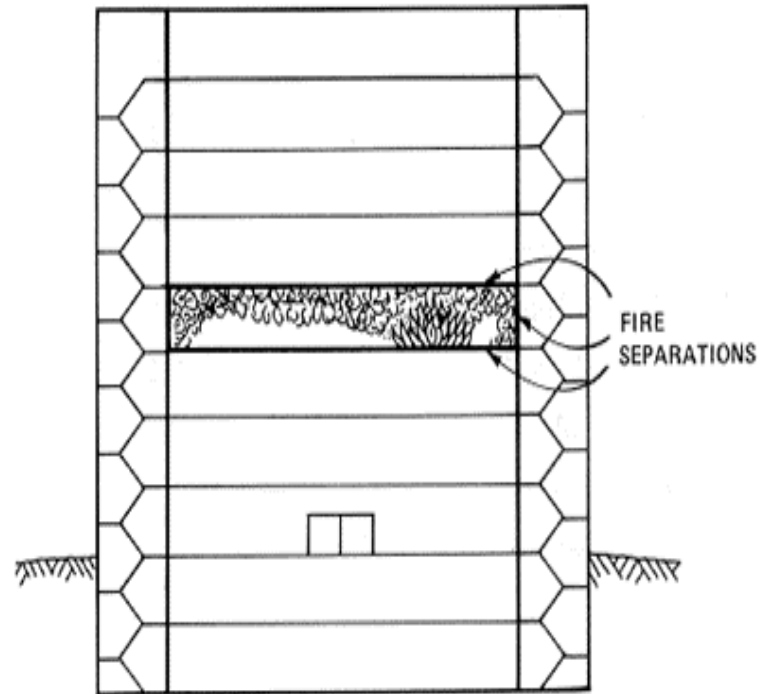

# Buildings are Safe Because....

- *Total Fire Protection Stats -  
North America High Rise*
  - *11,025 Tall Buildings - 20 + stories*
  - *70% in NY, SF, LA, CHI, HI, Toronto...*
    - *2/3 Canada's high rise built before 1985*
- = Compartmentation Primary in Older Structures*
- *Chicago, NY, Toronto – Older stock of buildings*
  - *SF, LA, HON – Earthquakes*

» *Source, Emporis.com*



# Buildings are Safe Because....

- *Total Fire Protection*  
= *Safer buildings...*
- *Compartmentation*
- *Sprinklers, Alarms,*
- *Egress Strategies*
- *NIST Reports...*



# Buildings are Safe Because....

- **National Institute of Standards & Technology**  
**‘NIST Reports - World Trade Center 7 –**
- **Chapter 4.6, 'Factors that could have mitigated structural collapse'**
  - *“..improved compartmentation in tenant areas to limit the spread of fires‘*
- *‘But first...DIIM’*



# Continuity – Barriers, Walls & Horizontal Assemblies

- Fire Walls and Floors –

- *Continuous Fire Resistance Rated Assemblies*

- Concrete
    - Concrete Block
    - Plaster
    - Gypsum Block
    - Gypsum Board / ‘Drywall’
    - Floor/Ceiling Assemblies

***“Tested & Listed Wall/Floor Systems”***





# Continuity

## Effective Compartmentation Features



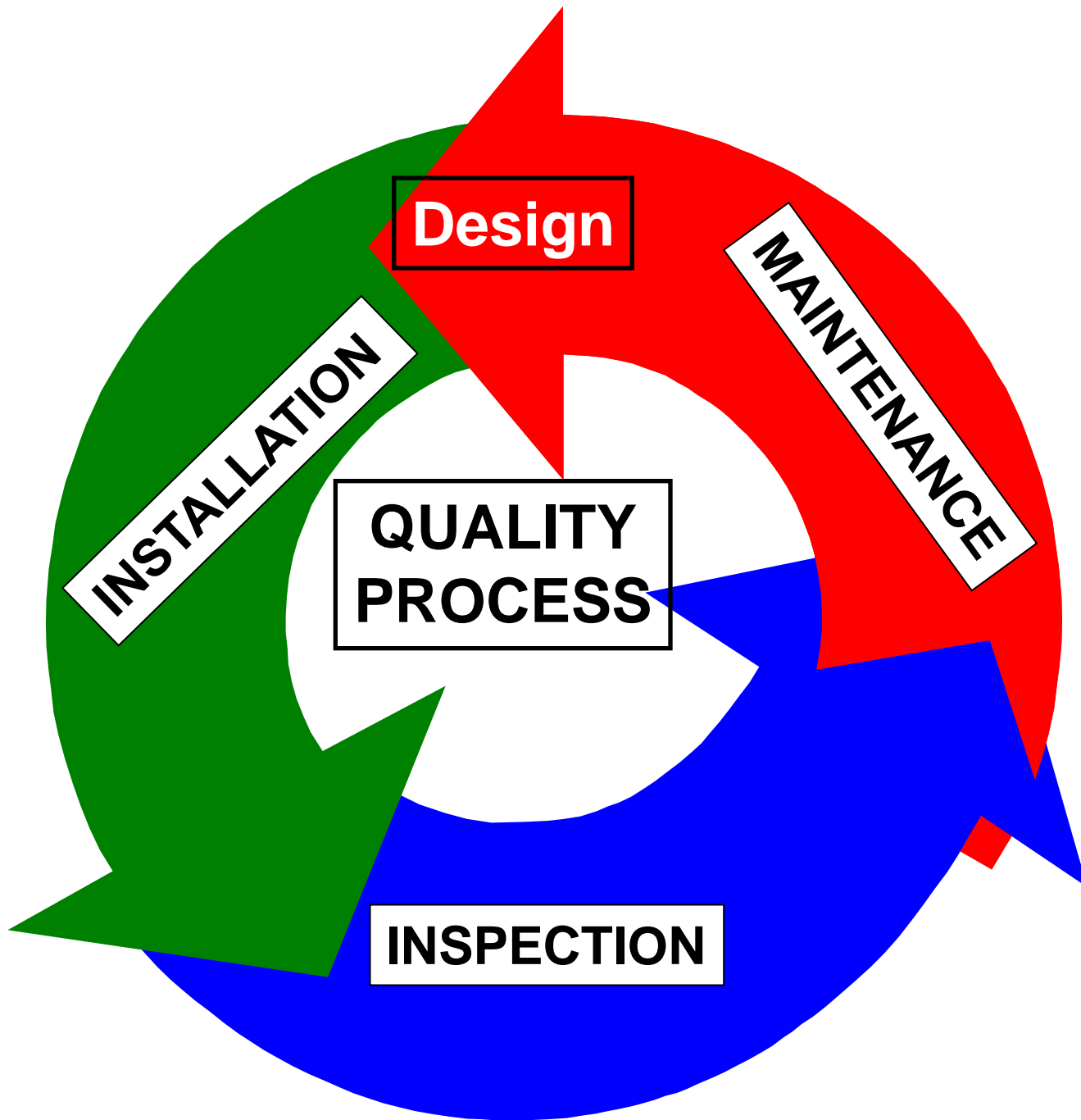

# Firestopping for Continuity

## DI – Design & Installation – Listed Systems

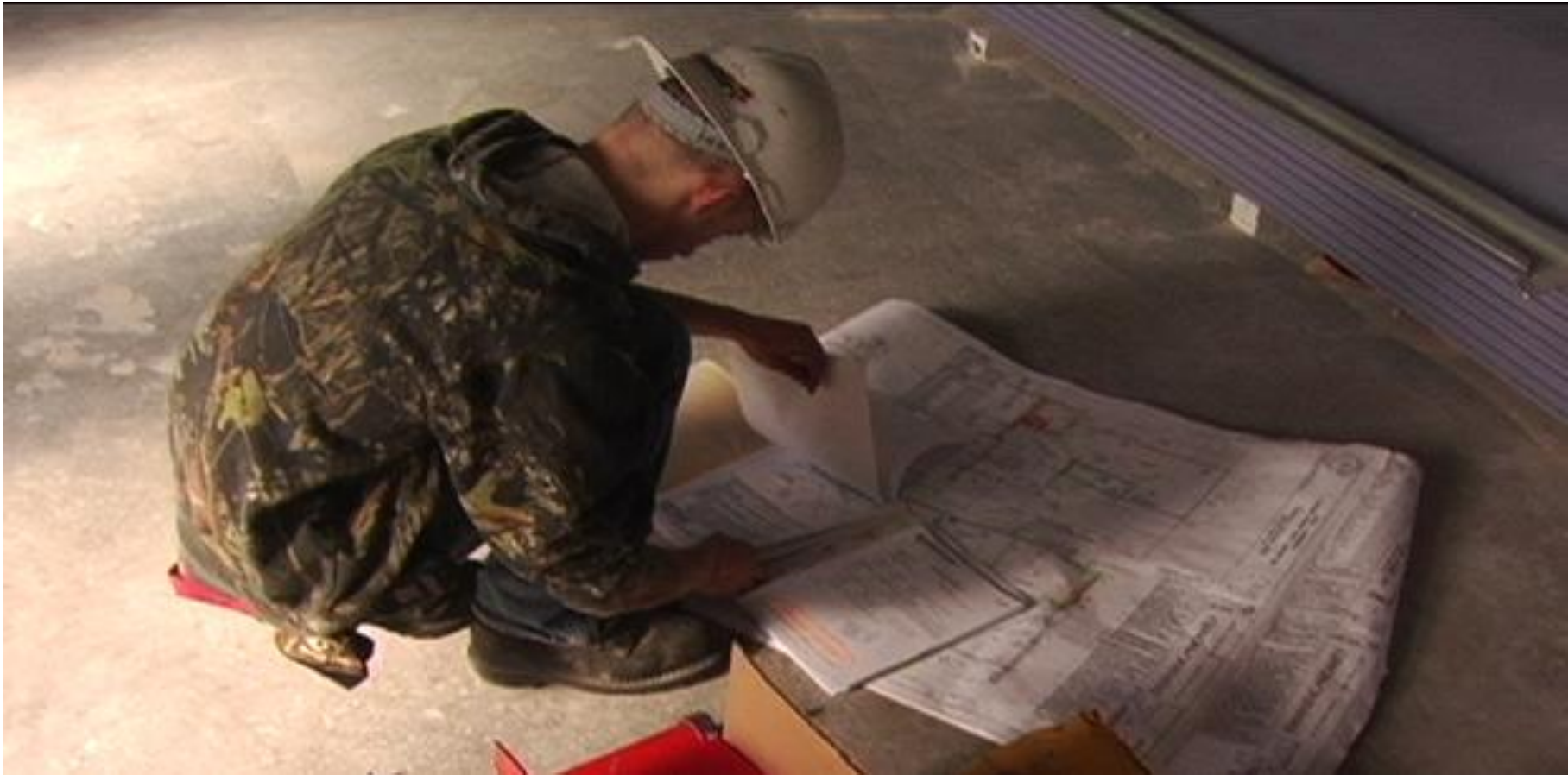

# Firestopping for Continuity

## DI – Listed Systems

System No. C-AJ-1160  
 I Rating—2 Hr  
 T Rating—0 Hr

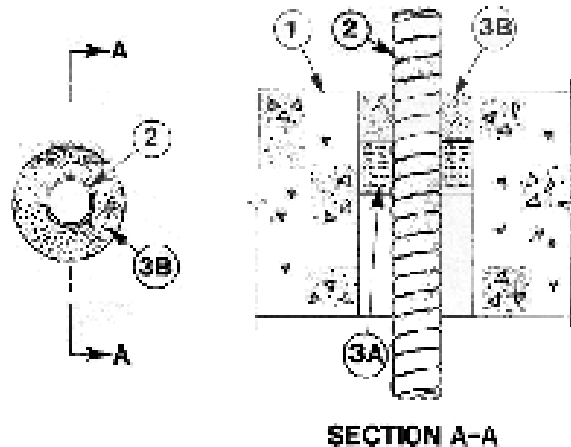

- Floor or Wall Assembly**—Min. 4-1/2 in. thick lightweight or normal weight (100 to 150 pcf) concrete. Wall may also be constructed of any UL Classified Concrete Block\*. Base of floor or through opening in floor or wall assembly to be 1/8 in. to 1-1/2 in. larger than diam of flexible metal conduit (Item 2) installed in through opening. Max diam of opening is 6 in. See Concrete Block (LAC) category in the Fire Resistance Directory for names of manufacturers.
- Through Penetrating Product\***—Max 4 in. diam (or smaller) pipe, or max 3/4 in. diam (or smaller) aluminum Flexible Metal Conduits. Max one flexible metal conduit to be installed near center of circular through opening in floor or wall assembly. Flexible metal conduit to be rigidly supported on both sides of floor or wall assembly.
- Packing Material**—Max 1 in. thickness of organic (polyimide slice) fiber blanket or mineral wool batt insulation firmly packed into opening as a permanent form. Packing material to be recessed into 1 in. from top surface of floor or from both surfaces of wall.
- FILL, Void or Cavity Material\*\***—Caulk—Applied to fill the annular space around the flexible metal conduit. In floor, a min 2 in. depth of fill material to be installed flush with top surface of floor. In walls, a min 1 in. depth of fill material to be installed flush with wall surface on both sides of wall assembly.

Minnesota Mining & Mfg. Co.—TF 2500\*

\*Bearing the UL Classification Marking

†Bearing the UL Listing Mark

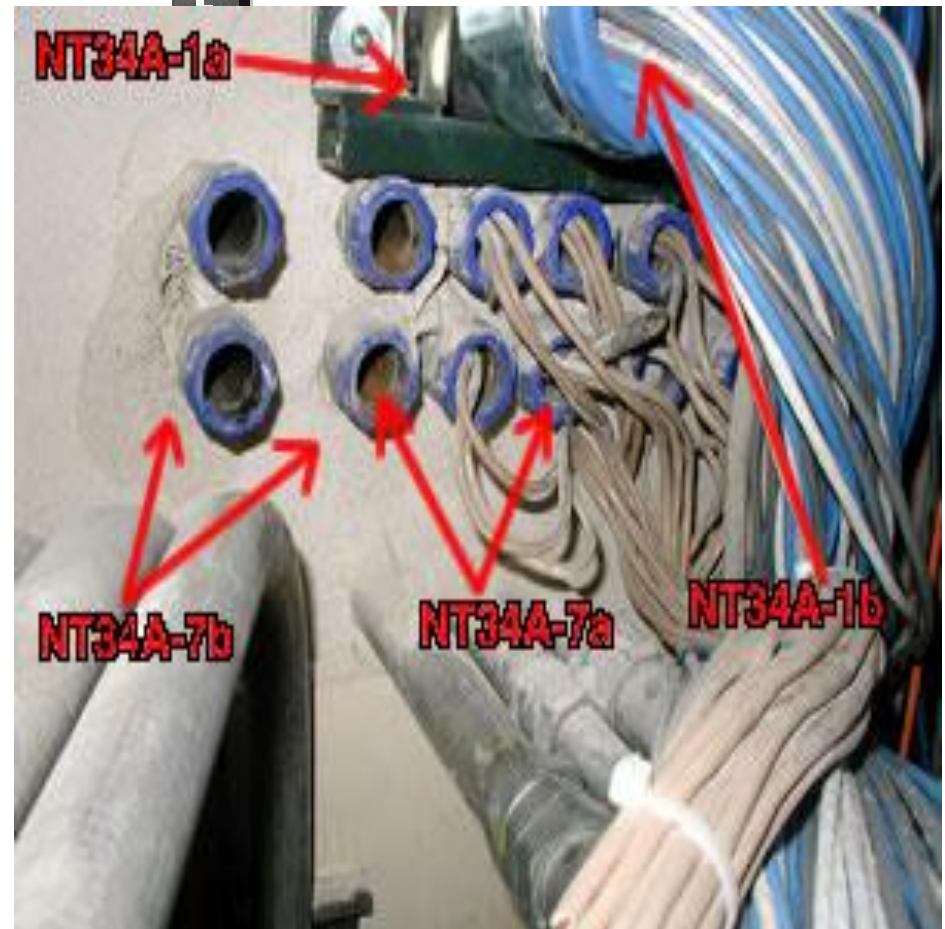

# Firestopping for Continuity

- **Firestop Products Become Firestop Systems --**
  - “A Specific field erected construction, consisting of an assemblage of materials to prevent the spread of fire through openings in fire rated walls and floors using ASTM E814-E1966 / UL 1479-UL2079 / **FM 4990**, ULC-S-115, ASTM E-2307 as the test method...”
  - **Testing = Suitability statement for use of a firestop product in a specific system application**

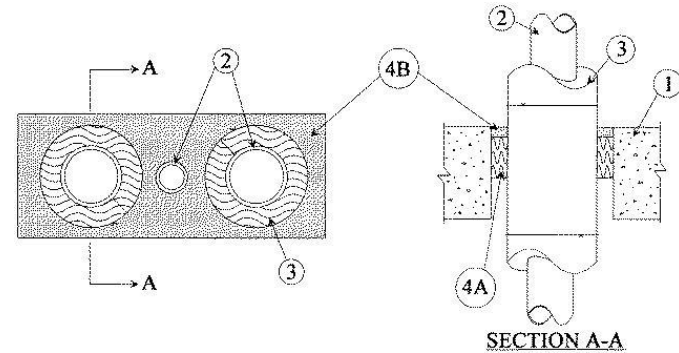

# Firestopping for Continuity

## Firestop Products

- **Sealants**
  - Silicone, Latex, Intumescent
- **Wrap Strips**
  - “Thick, Thin, Wide, Less Wide”
- **Putties**
- **Pillows**
- **Composite Sheets**
- **Bricks / Plugs**
- **Pre Fabricated Kits**
- **Mortar**
- **Spray Products**



# Firestop Materials, Systems & Physical Properties

- **Serve Building Needs**
  - Smoke
  - Germs
  - Chemical Resistance – Cleaning?
  - Chemical, Biological, Radiation?
- **Product Types**
  - Intumescent, Latex, Silicone
  - Ablative
  - Endothermic



# Fire/Smoke Dampers & Firestops

- Dampers are UL 555, 555S Listed *Systems*
  - Installed - manufacturer's instructions & Systems
  - Angles @ wall interface - no sealants
- Firestop Products/Systems –
  - UL 1479 & UL 555/555S

**Consult the Damper  
Manufacturer & the  
Authority Having  
Jurisdiction**

Greenheck Graphic





# Fire/Smoke Dampers Firestop Installation

- Combination Fire Smoke Dampers
- Multi-blade Fire Dampers
- Underfloor applications
- Max. size 72" W x 96" H
- SYSTEM...Proven Fire Resistance

» Greenheck Graphic



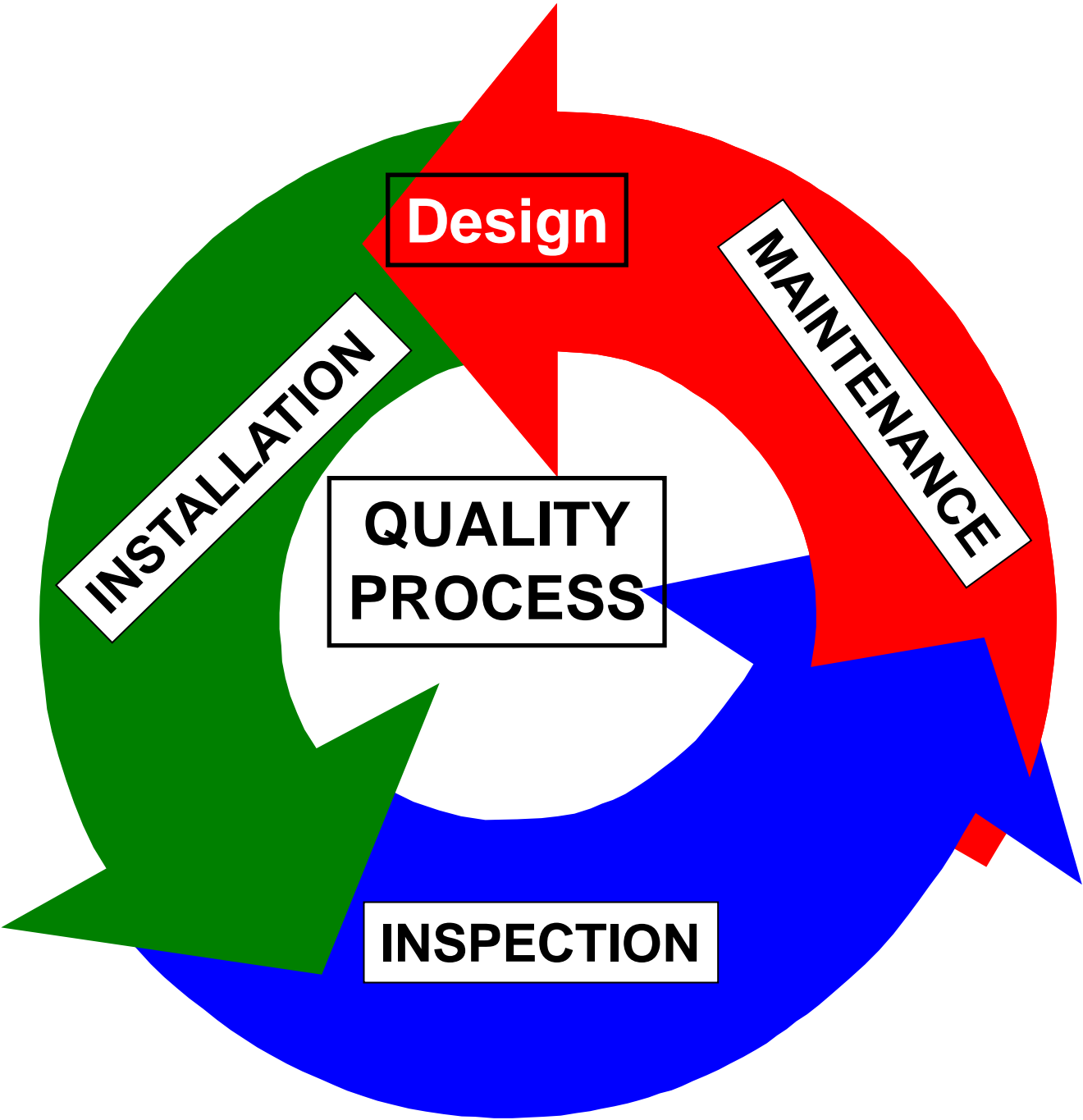

**Design**

**MAINTENANCE**

**QUALITY  
PROCESS**

**INSPECTION**

**INSTALLATION**

# DI- Design & Installation

## SYSTEMS SELECTION

## SYSTEMS ANALYSIS

Who's Responsible, How to Choose???

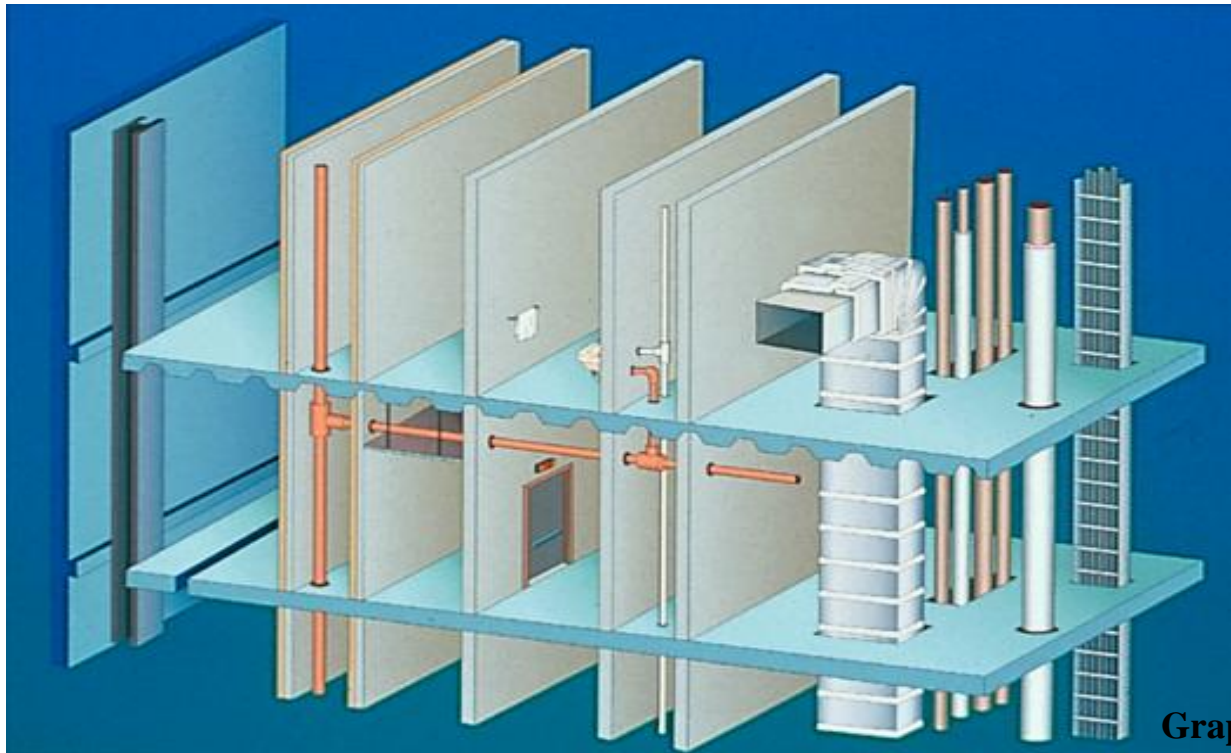

Graphics – STI

# Firestopping for Continuity

## Products become **SYSTEMS**

- **‘Field Erected Construction...Tested to...’**
  - Standards - ASTM E814/UL 1479–UL 2079, ASTM E 1966, ASTM E 2307, ULC S-115, FM 4990
  - **F Rating - Flame**
  - T Rating – Temperature
  - H Rating – Hose
  - **L Rating – Smoke**
  - **W Rating – Water**

Graphics – 3M



# Firestopping for Continuity

## Products become **SYSTEMS**

This category covers **firestop systems**, which are specific constructions consisting of a wall or floor assembly, a penetrating item passing through an opening in the wall or floor assembly, and the materials designed to prevent the spread of fire through the openings.....

[UL Guide Information]

# Firestopping for Continuity

## Products become SYSTEMS

The specifications for materials in a firestop system and the assembly of the materials are details that directly relate to the established ratings. Information concerning these details is described in the individual systems.

**The hourly ratings apply only to the complete systems.** Individual components are designated for use in a specific system to achieve specified ratings. The individual components are not assigned ratings and are not intended to be interchanged between systems.....

[UL Guide Information]

# Firestopping for Continuity

## Products become SYSTEMS

Additionally, **the substitution or elimination of components required in a system should not be made** unless specifically permitted in the individual system or in these general guidelines.

[UL Guide Information]

# Firestopping for Continuity

## Products become SYSTEMS

- The firestop systems covered under this category have been investigated with a **positive furnace pressure** differential of at least 0.01 in. of water maintained at a distance of 12 in. below horizontal test assemblies and 0.78 in. below the fill materials surrounding the penetrating items passing through vertical test assemblies.
- The certifications of firestop systems contemplate installation in **heated and air conditioned environments** unless stated otherwise in the description of the system.

[UL Guide Information]



# Firestopping for Continuity

## Products become SYSTEMS

- **F Rating - Flame**

**F RATING.** The time period that the *through-penetration firestop system* limits the spread of fire through the penetration when tested in accordance with ASTM E 814 or UL 1479. [IBC 2015, Section 202]

# Firestopping for Continuity

## Products become **SYSTEMS**

- **F Rating - Flame**

The F-rating criteria prohibits flame passage through the system and requires acceptable hose-stream test performance. [UL Guide Information]

# Firestopping for Continuity

## Products become SYSTEMS

- **T Rating – Temperature**

**T RATING.** The time period that the *penetration firestop system*, including the penetrating item, limits the maximum temperature rise to 325°F (163°C) above its initial temperature through the penetration on the non fire side when tested in accordance with ASTM E 814 or UL 1479. [IBC 2015, Section 202]

The T-rating criteria prohibits flame passage through the system and requires the maximum temperature rise on the unexposed surface of the wall or floor assembly, on the penetrating item and on the fill material not to exceed 325°F (181°C) above ambient, and requires acceptable hose-stream test performance. [UL Guide Information]

# Firestopping for Continuity

## Products become SYSTEMS

- **L Rating – Smoke**

**L RATING.** The air leakage rating of a *through penetration firestop system* or a fire-resistant *joint system* when tested in accordance with UL 1479 or UL 2079, respectively. [IBC 2015, Section 202]

# Firestopping for Continuity

## Products become SYSTEMS

- **L Rating – Smoke**

The L-rating criteria determines the amount of air leakage, in cu feet per minute per square foot of opening (CFM/sq ft) or in cu feet per minute per unit (CFM/unit) for fixed-size opening units, through the firestop system at ambient and/or 400°F air temperatures at an air-pressure differential of 0.30 in. W.C. The L ratings are intended to assist Authorities Having Jurisdiction and others in determining the suitability of firestop systems for the protection of penetrations and miscellaneous openings in floors and smoke barriers for the purpose of restricting the movement of smoke in accordance with ANSI/NFPA 101, "Life Safety Code." [UL's Guide Info]

# Firestopping for Continuity

## Products become **SYSTEMS**

### **W Rating – Water**

The Class 1 W rating determines the capability of the firestop system to maintain watertightness of the penetration through a floor or wall construction at ambient air conditions under **3 ft of water pressure head (1.3 psi) for a period of 72 hours**. The W rating may be applicable for building structures whose floors are subjected to incidental standing water and/or for buildings that house critical equipment as described in ANSI/NFPA 75, "Fire Protection of Information Technology Equipment," and ANSI/NFPA 76, "Fire Protection of Telecommunications Facilities."

# Firestopping for Continuity

## Products become **SYSTEMS**

### W Rating – Water

Acceptance is based upon the ability of the firestop system to withstand the applied pressure without the passage of any water through the firestop system. After the Class 1 watertightness test, the firestop system is conditioned in accordance with the requirements of ANSI/UL 1479 and the fire and hose stream tests described in the standard are conducted.

The W rating is intended to assist Authorities Having Jurisdiction and others in determining the suitability of firestop systems in applications where submersion in water may be a factor.

# Firestopping for Continuity

## Products become SYSTEMS

- **F Rating - Flame**
  - T Rating – Temperature
  - H Rating – Hose
  - **L Rating – Smoke**
  - W Rating – Water





# Products become Systems

## Hose Stream = Impact/Shock Test





U.L. SYSTEM NO. CAJ1155  
METAL PIPE THROUGH A SLEEVE IN CONCRETE FLOOR OR WALL

F RATING = 3-HR.

T RATING = 0-HR.

L RATING AT AMBIENT = LESS THAN 1 CFM/SQ. FT.

L RATING AT 400°F = 4 CFM/SQ. FT.

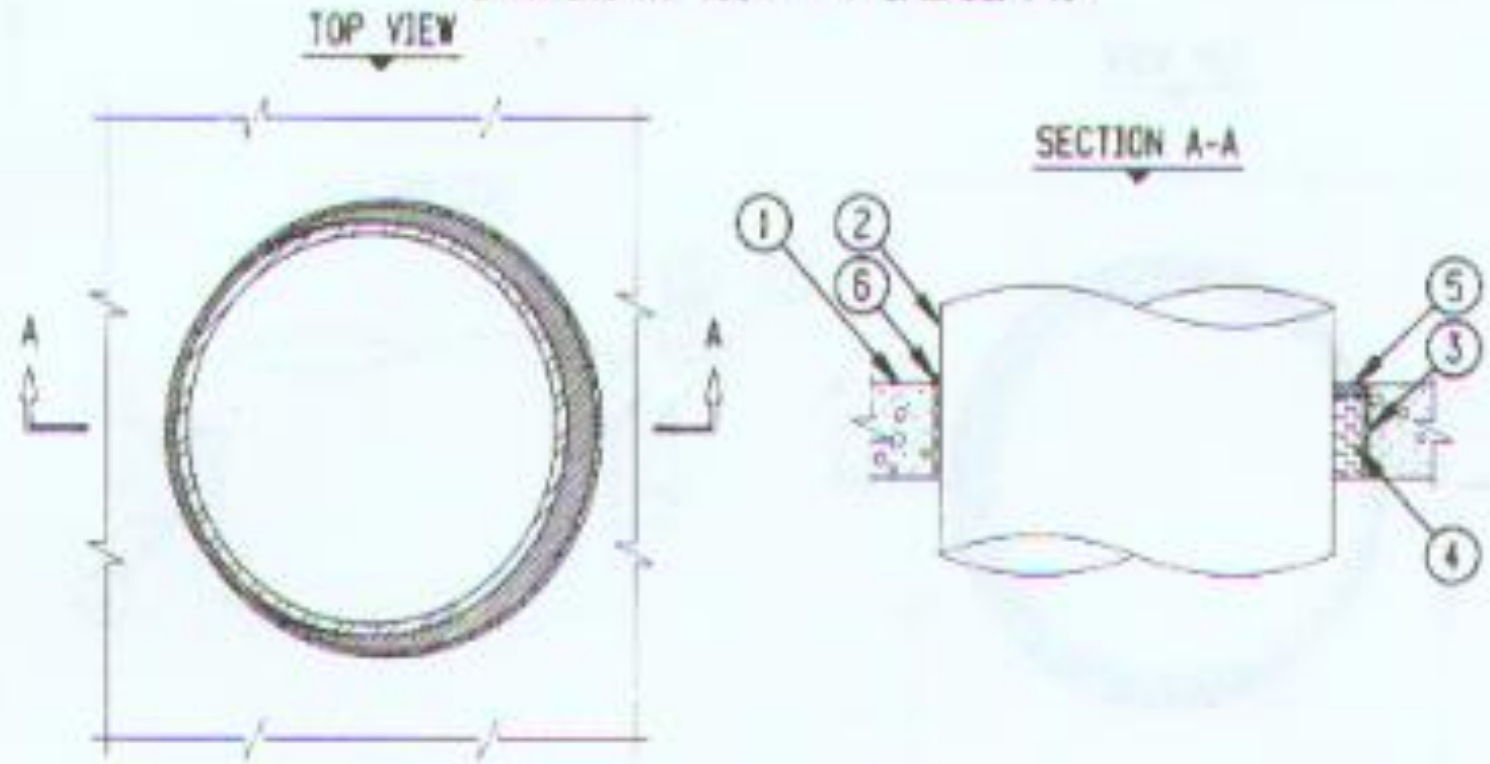

CAJ1155 000798

1. FLOOR OR WALL ASSEMBLY :

- A. MINIMUM 4-1/2" THICK LIGHTWEIGHT OR NORMAL WEIGHT CONCRETE FLOOR.
- B. U.L. CLASSIFIED CONCRETE BLOCK WALL (MINIMUM 8" BLOCK).

2. PENETRATING ITEM TO BE ONE OF THE FOLLOWING :

- A. MAXIMUM 20" DIAMETER STEEL PIPE.
- B. MAXIMUM 6" DIAMETER COPPER PIPE.



Fire Stop Technologies, Inc.



Fire Stop Technologies, Inc.

## Gypsum Wall assembly running up to concrete over metal deck

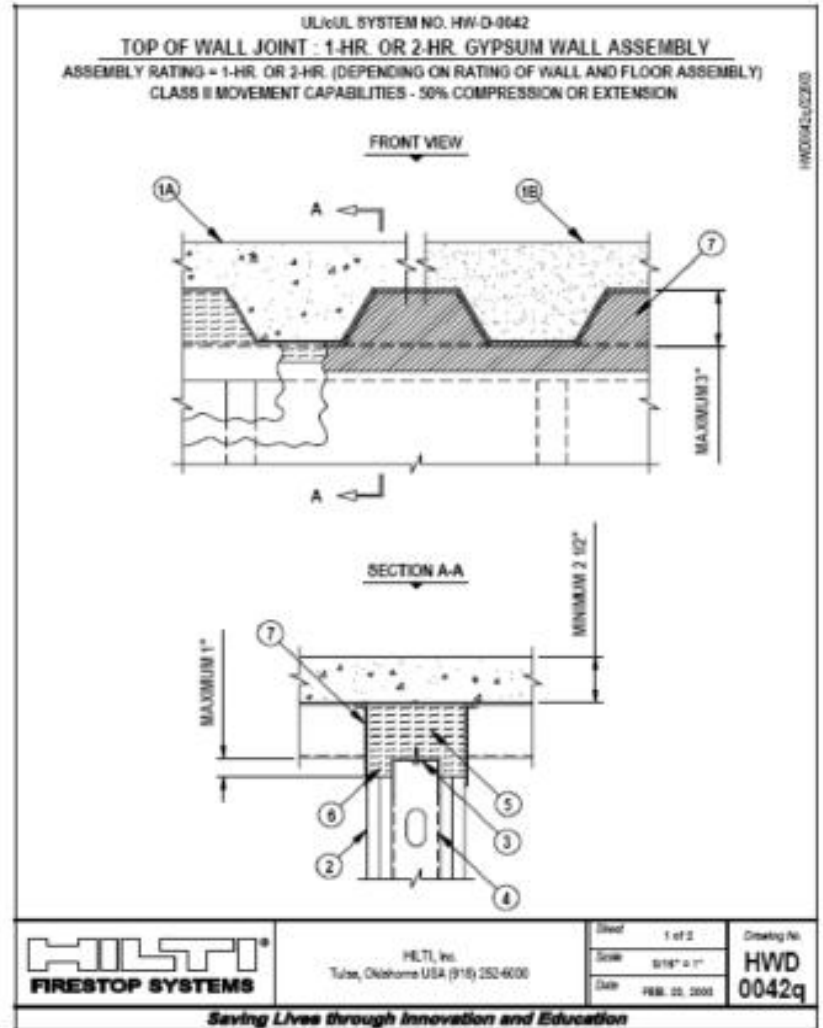

# How do Contractors Select Systems & Inspection Agencies Analyze?

- Wall or Floor Construction Type, Rating
- Wall or Floor Thickness
- Penetrating Item, Coverings
- Size, Type, Thickness
- Annular Space Sizes
- Joint / Gap Sizes
- Backing Materials
- Fill Material(s)

***= Rated Firestop System***



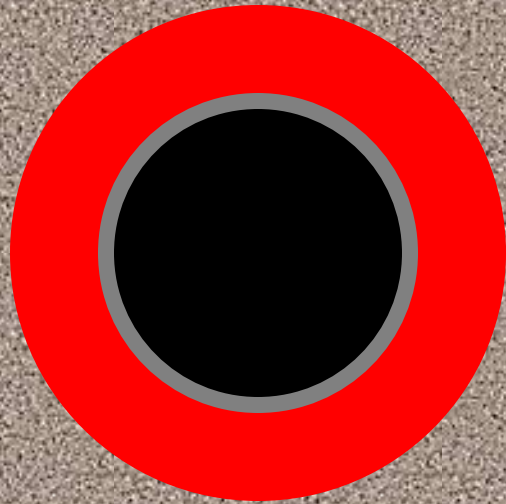

**1. Centered**

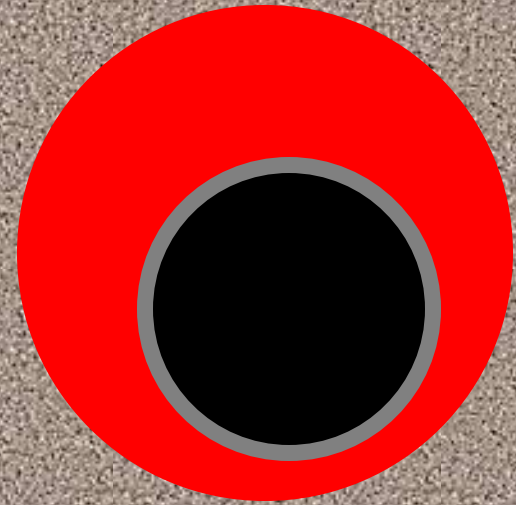

**2. Off-Centered**

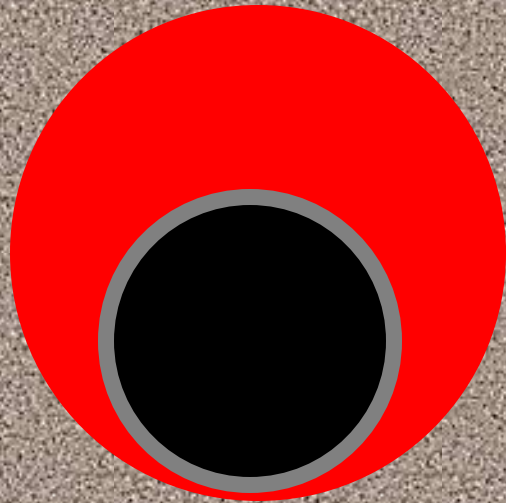

**3. Point Contact**

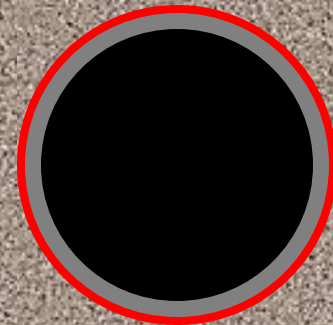

**4. Continuous Point Contact**

# Engineering Judgments/EFRRRA

- Field or other Variances to Tested and Listed Systems?
  - Impractical or Impossible
  - No System Exists
- Why???
  - Lack of Planning
  - Unique Conditions



# Engineering Judgments/EFRRA

- Variances to Systems at Site ? – Now What...
  - **First Action in Process**
    - **Find another system** – Same Manufacturer
    - **Find another system** – Different Manufacturer
    - **If no system exists in either case....**
  - **Second Action** –
    - *Equivalent Fire Resistance Rated Assembly, EFRRA*
    - *Engineering Judgment* – “EJ”
  - *Based on engineering, IFC Protocol*



## **IFC Guidelines for Evaluating Engineering Judgment Guidelines**

‘Construction industry professionals, building officials, fire officials, firestop contractors and **other stakeholders need appropriate guidelines for evaluating and using such judgments.**

As such, IFC developed *Recommended IFC Guidelines for Evaluating FireStop Systems in Engineering Judgments.*

# **IFC EJ Guidelines - Engineering Judgments for firestop systems should:**

- 1. Not be used in lieu of tested systems when available;**
- 2. Be issued only by a firestop manufacturer's qualified technical personnel or in concert with the manufacturer by a knowledgeable registered Professional Engineer, Fire Protection Engineer, or an independent testing agency that provides listing services for firestop systems;**
- 3. Be based upon interpolation of previously tested firestop systems that are either sufficiently similar in nature or clearly bracket the conditions upon which the judgment is to be given. Additional knowledge and technical interpretations based upon accepted engineering principles, fire science and fire testing guidelines (e.g. ASTM E 2032 – Standard Guide for Extension of Data from Fire Endurance Tests, ULC Subject C263E – Criteria for Use in Extension of Data from Fire Endurance Tests, or ASTM E2750 – Standard Guide for Extensions of Data for Penetration Seals) may also be used as further support data;**

# **IFC EJ Guidelines**

**Engineering Judgments for firestop systems should:**

- 4. Be based upon full knowledge of the elements of the construction to be protected, the understanding of the probable behavior of that construction and the recommended firestop system protecting it were they to be subjected to the appropriate Firestop Standard Fire Test method for the rating indicated on the Engineering Judgment;**
- 5. Be limited only to specific conditions and configurations upon which the engineering judgment was rendered and should be based upon reasonable performance expectations for the recommended firestop system under those conditions;**
- 6. Be accepted only for a single, specific job and project location and should not be transferred to any other job or project location without thorough and appropriate review of all aspects of the next job or location's circumstances.**

# **IFC EJ Guidelines - Basic Presentation Requirements**

**Proper EJ's should:**

- 1. Be presented in appropriately descriptive written form with or without detail drawings where appropriate;**
- 2. Clearly indicate that the recommended firestop system is an EJ;**
- 3. Include clear directions for the installation of the recommended firestop system;**
- 4. Include dates of issue and authorization signature as well as the issuer's name, address and telephone number;**
- 5. Reference tested system(s) upon which design (EJ) is based on;**
- 6. Identify the job name, project location and firm EJ is issued to along with the non-standard conditions and rating supported by the EJ;**

# **IFC EJ Presentation Guidelines – What’s Seen?**

- 7. Have proper justification (i.e. UL, Intertek or other independent laboratory system(s) and or opinions);**
- 8. Provide complete descriptions of critical elements for the firestop configuration. These should include, but not be limited to the following:**

## **a. Basic, Common**

- Type(s) of assembly used or being penetrated;**
- Rating supported by the EJ.**

## **b. Through Penetrations**

- Penetrating item(s) (type, size, etc.);**
- Annular space requirements, (minimum, maximum, actual, nominal, etc.)**
- Opening size;**
- Firestop product(s) to be used, type and amount (thickness if applicable);**
- Accessory items(s) (i.e. anchors, backing material, etc.)**

## **c. Joints**

- Joint Width (installed width, nominal)**
- Movement Capability;**
- Movement Class (thermal wind sway, seismic);**
- Accessory item(s) (i.e. insulation type, thickness and compression, etc.)**

# **IFC EJ Presentation Guidelines – What’s Seen?**

**d•Duct Enclosure Systems – SEE [www.Firestop.org](http://www.Firestop.org)**

**e• Firestop System – annular space dimensions, floor/wall construction, design number, components, installed thickness.**

**f. Perimeter Fire Barrier Systems –**

- Type(s) of assembly used or being penetrated;**
- Hourly Rating required**
- Closest Listed System upon which the EJ is based**
- Joint Width**
- Static or Dynamic**
- Safing Insulation Types), thickness and compression, etc.**
- Five Basic Principles**
  - 1. Mechanical Attachment of the Spandrel Insulation**
  - 2. Protection of the Mullions**
  - 3. Compression Fitting and Orientation of the Safing Insulation**
  - 4. Installation of a Reinforcement Member(s), stiffener, at the safe-off area behind the spandrel insulation.**
  - 5. Firestop Coating, type, thickness,**

# IFC EJ Presentation Guidelines – What's Seen?

## *f• Continuity Head-of-Wall Joints*

- Joint Width, (installed width, nominal)*
- Movement Capability*
- Movement Class – (thermal, wind sway, seismic)*
- Accessory Item(s) (i.e. insulation type, thickness, compression, etc.)*

*IFC recommends that these guidelines be considered when evaluating whether any firestop system engineering judgment meets minimal requirements. Questions concerning the EJ request should be addressed to the initiator of the judgment.*

*FCIA NOTE: Request manufacturer statement that they believe the EJ/EFRR shall pass a Fire Test to ASTM E-814,E-1966, UL 1479, UL 2079, ASTM E 2307...*

# INSTALL FIRESTOP SYSTEM

## Firestop Sealant, MW installation to Tested and Listed System Limits = Firestop System



Pack

1



Apply Sealant

2



Tool/Smooth

3

**Walls - BOTH SIDES**



# Properly Tooled/Smoothed Firestop Sealants



# Sleeved Pipes



# Correct Collar or Sealant Must Be Selected for Combustible Penetrations

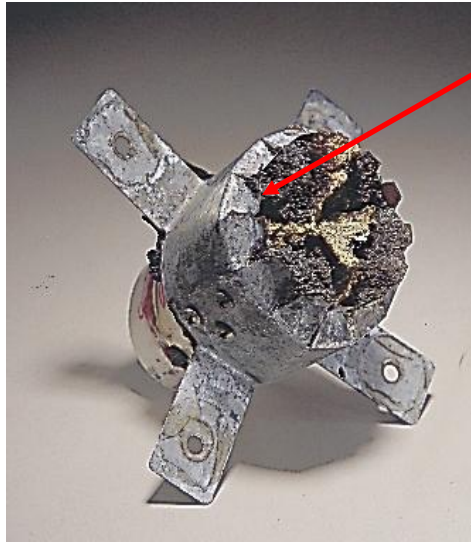

Charred Pipe

Knot formed from  
Collapsing pipe



**Fire-Side View**

**Non-Fire Side View**

- Intumescent sealant – wrap strip – collars expand, fills voids made as penetrating items warp, move or burn away....

# Intumescent Wrap Strips and Steel Collars

- **Key Points - Restricting Collars**
  - Fastening Tabs – 90 degree bends for expansion
  - Directional Tabs
  - Bands

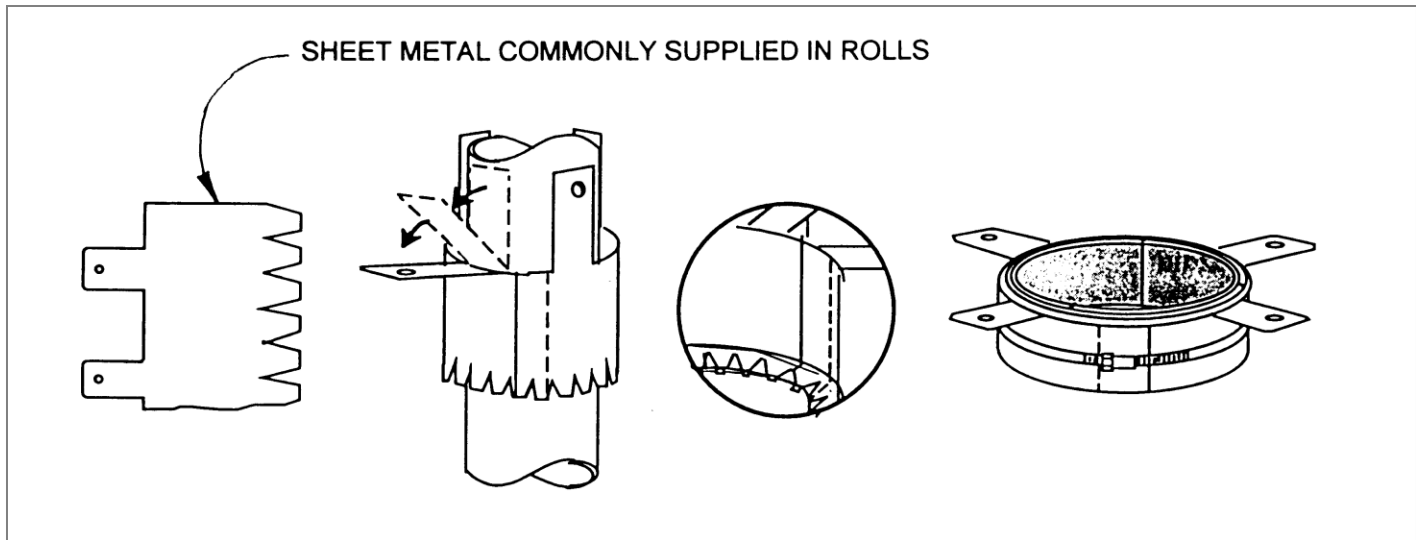

# Unlisted, Untested Firestop Systems



# Firestopping for Safety

## Unlisted, Untested Firestop Systems



# Joint Compound



# Incomplete is ineffective





# Great Stuff

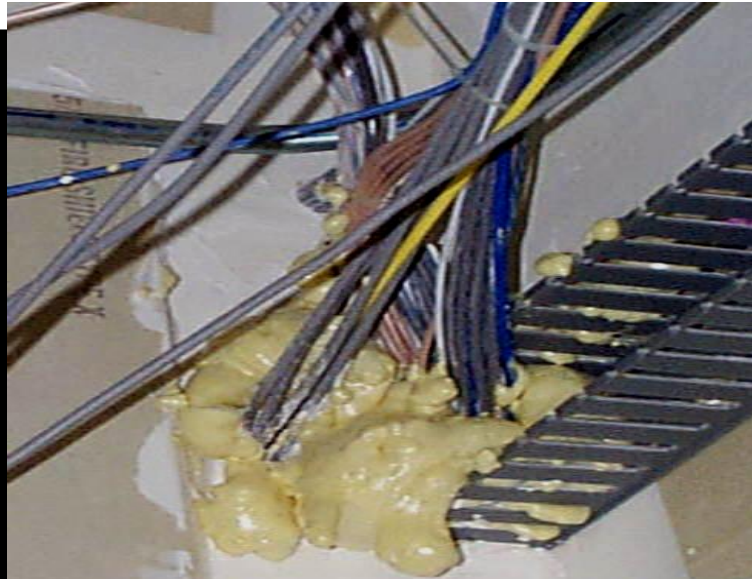

**Graphics – Firestop Solutions**

# Fire/Smoke Dampers & Firestops

- Dampers are UL 555, 555S Listed *Systems*
  - Installed to manufacturer's written instructions
  - Systems – Angles...no sealants...
- Firestop sealants –
  - UL 1479 & UL 555, 555S
  - OR...Voids at Damper Angle

***Consult the Damper  
Manufacturer & the  
Authority Having  
Jurisdiction***

Graphics - Greenheck



# Installing an Incorrect System May Void the Fire / Smoke Damper Manufacturer's Warranty



# Barriers With Breaches for Combustible Penetrants

- Plastic Penetrating items
- Multiple cables
- Some pipe insulations



# Firestop Joint Systems

- UL 2079, ASTM E 1966, ULC-S-115
  - “A joint system is a **specific construction** consisting of adjacent **wall and floor assemblies**, *and* **the materials** designed to prevent the spread of fire through a linear opening between the wall and / or floor assemblies”

- Definition

**JOINT.** The opening in or between adjacent assemblies that is created due to building tolerances, or is designed to allow independent movement of the building in any plane caused by thermal, seismic, wind or any other loading.

- Breach?
- Joint?
- Opening?



# Firestop Joint Systems

- UL 2079, ASTM E 1966, ULC-S-115
- **JOINT.** The opening in or between adjacent assemblies that is created due to building tolerances, or is designed to allow independent movement of the building in any plane caused by thermal, seismic, wind or any other loading. [IBC 2015]
  - Breach?
  - Joint?
  - Opening?



# Firestopping for Safety

- **Firestop Joint Systems – UL 2079**
  - Min. Positive Pressure – .01 Water, 12” below assy.
  - Movement Cycling
    - Class I – min. 500 cycles, min. 1 cycle / minute
    - Class II- min. 500 cycles, min. 10 cycles / minute
    - Class III-min 100 cycles, min. 30 cycles / minute
  - Fire Tested at Maximum Joint Width
  - No Load Bearing Characteristics, unless noted
  - Assembly, L or W Ratings

HILTI Graphic

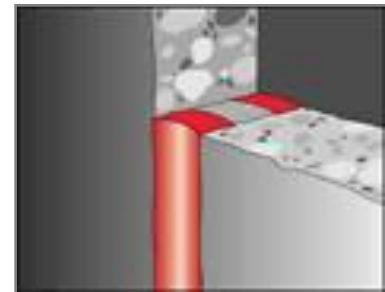



Fire Stop Technologies, Inc.



## Gypsum Wall assembly running up to concrete over metal deck

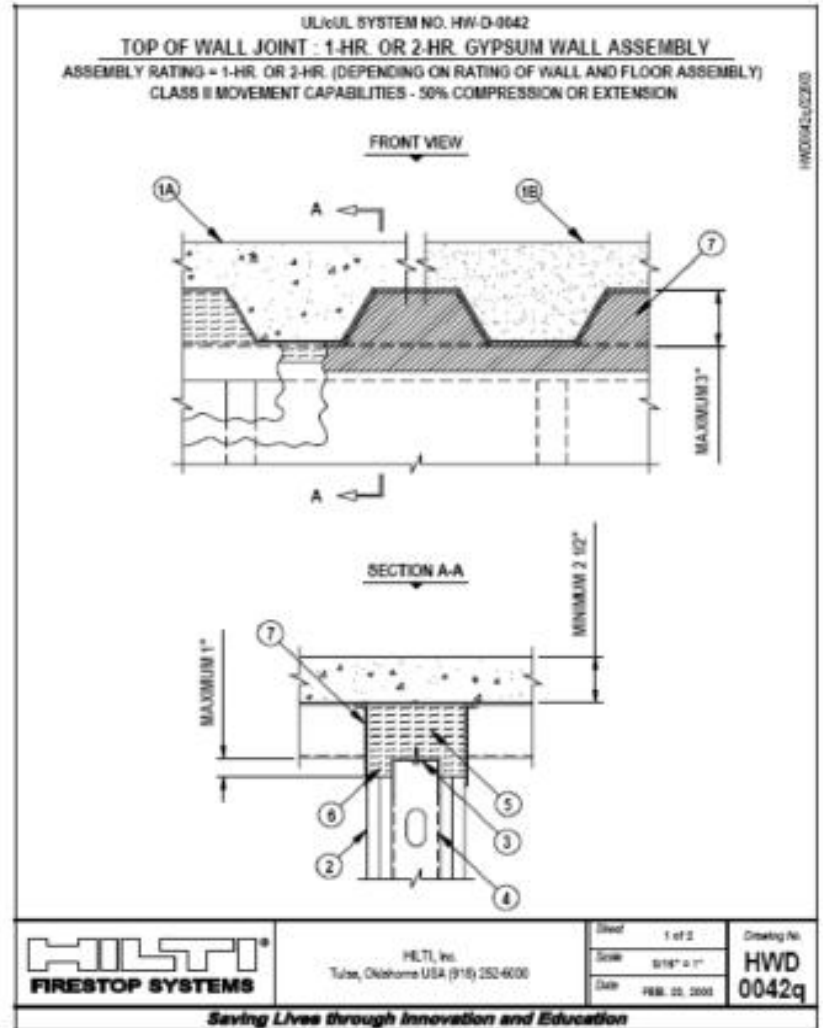



# Firestop Applications

**Floor to Wall**



**Top of Wall**



Fire Stop  
Technologies,  
Inc.

Graphics – Firestop Solutions

# Joints and Seams

## Head of Wall



# Joints and Seams

## I-Beam to Fluted Deck



# Breaches made for Penetrations Head of Wall



# Unacceptable



# Results of Improperly Installed Mineral Wool



# Firestop Perimeter Fire Containment Systems

- Firestop Perimeter Systems

**Definition – ASTM E 2307**

- “A Perimeter Fire Containment System is a **specific field erected construction** consisting of a floor with a fire resistance rating, and an exterior curtainwall with no hourly resistance rating, and the fill material installed between the floor and the curtain wall to prevent the vertical spread of fire in a building.”



# Firestop Perimeter Fire Containment Systems



Graphic – Intertek



# Backing/Damming/Forming Fiber Orientation

- Compressed mineral wool inserted ‘vertical fibers’ allows movement between assemblies

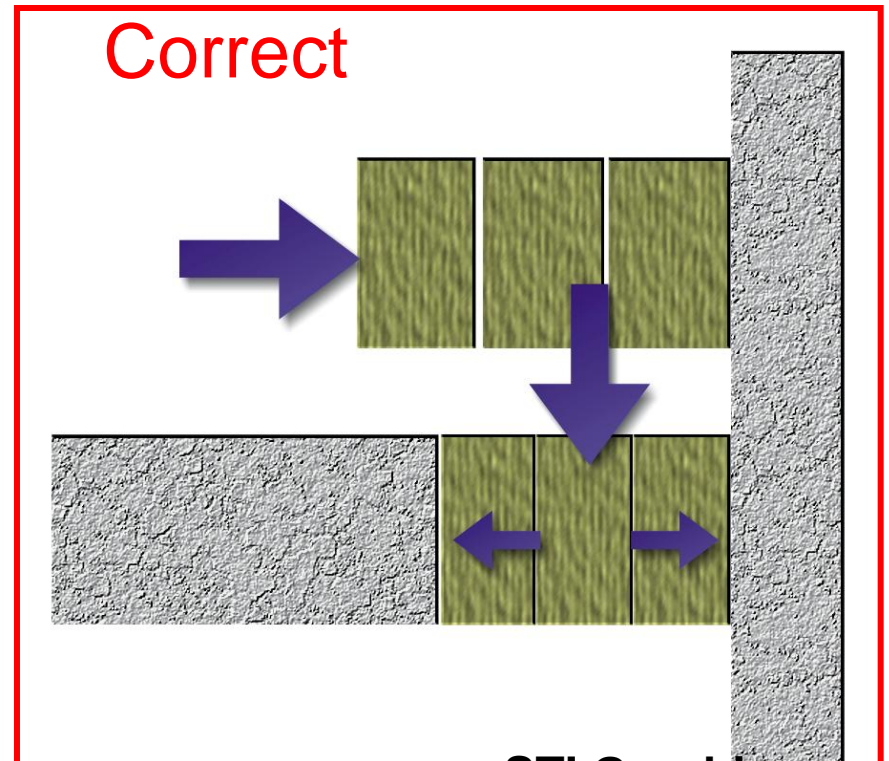
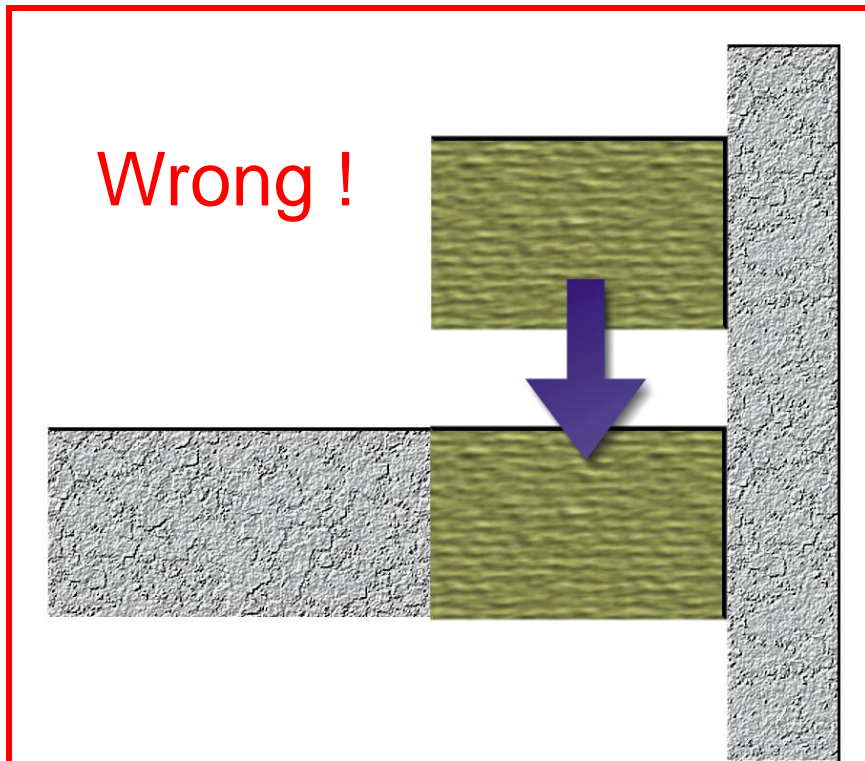



**STI Graphic**

# Firestop Installed at Perimeter of Floors at Curtainwall



# *Safer Buildings ...*

*– Tamweel Apartment Tower, Dubai*



# *Safer Buildings ...*

- *Safer Buildings - Tamweel Apartment Tower...*

**‘Tamweel Tower  
fire started by  
cigarette butt, say  
Dubai Police’  
[thenational.ae](http://thenational.ae)**

**Insulation?  
Thermal Barriers?**



# Firestop Products Become Systems

## Install to SYSTEM



# I- Installation

Who's Responsible, How to Choose???

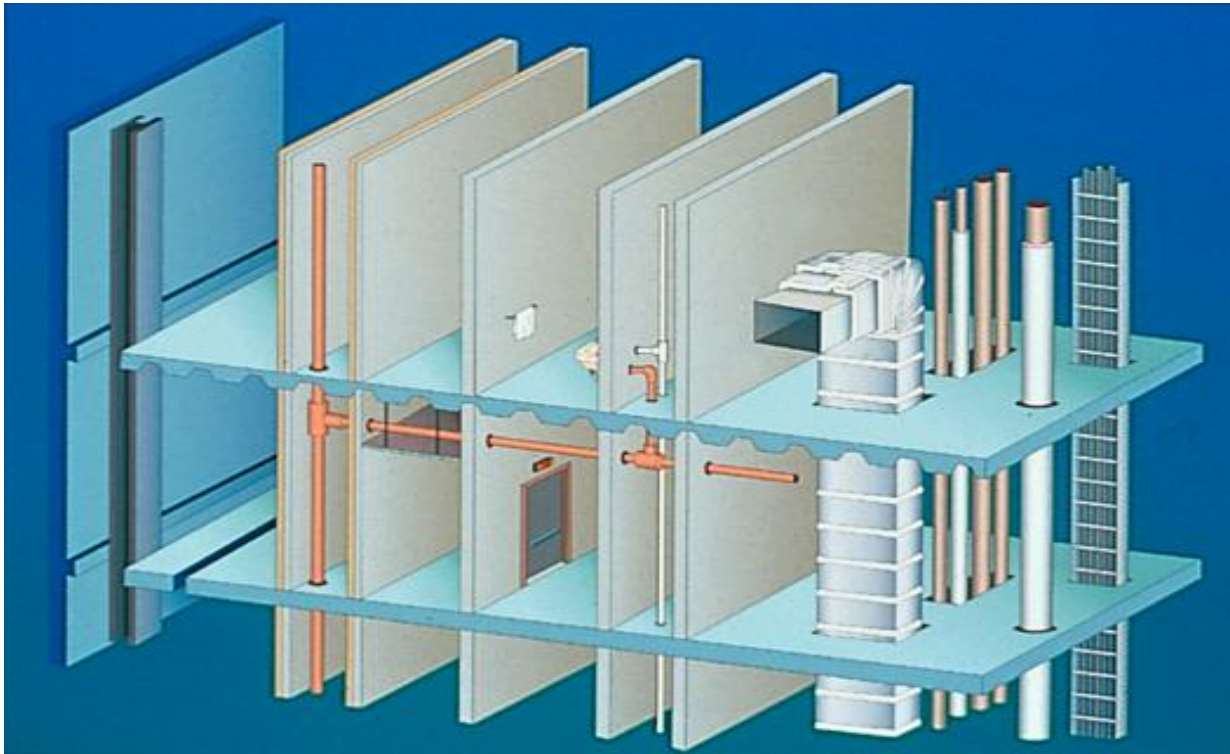

Graphics – STI

# Installation – Who?

- Firestopping wrong, missing
- Systems Documentation?
- As Built Documentation??

*Conclusion –*

*Without Single Firestopping Trade....*

*fire & life safety risks*

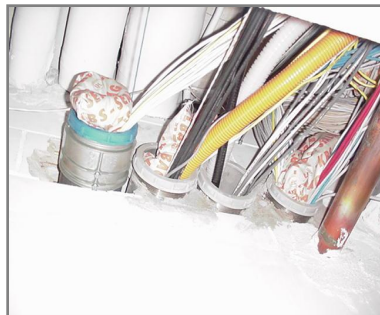

*Adler Photo*



# 3 Firestop Installation Methods

- **Each Trade**
  - “He/She who pokes hole, fills hole”
- **Multiple Contracts**
  - Firestop Contractors, Trades
- **Single Source Firestop Contractor**
  - *FCIA Member in Good Standing*
  - *FM 4991, UL-ULC Qualified*

# Why Contractor Qualifications?

- **Firestopping** Ratings - F, T, H, L W
- **Zero Tolerances?**
  - Annular Space Sizes, Gap Sizes
- **Product Properties**
  - Movement
  - Compatibility
  - Storage, Application, Curing Temps
- **SYSTEMS DOCUMENTATION**

# Firestop Contractor Qualifications

## 1. Bought at Hardware Store, etc.

- Contractor or Individual?

## 2. Manufacturer Trained Individuals

- 1 hour program
- 1/2 day program
- 2 day education

## 3. ULC Qualified, FM 4991 Approved Companies

- 3<sup>rd</sup> Party Verified *Company* Management System
- *Individuals* Pass 3<sup>rd</sup> Party Exam
- *Individual* Knowledge – FCIA MOP
- All Manufacturers Products Covered
- *Company gets Approved or Qualified, not Individual*

# Firestop Contractor Qualifications

- **FCIA Member?**
- Workforce
  - Educated as Firestop/Containment Workers
- Bonding Capability?
- Project References & Experience
- **FM 4991 Approved Contractor?**
- **UL or ULC Qualified Contractor?**

# Contractor Qualification

## FM & UL/ULC – 5 Components

1. Contractor Quality Management System
2. Office Facility Audit
3. Jobsite Audit
4. Employ a person
  - UL/FM Firestop Exam @ 80% or better
  - DRI if employed by Approved/Qualified Firm,
    - *Designated Responsible Individual (DRI)*
5. Annual Audit



# **1 & 2. Office Audit of Company Management System Manual**

- Write Management System
  - Projects Managed Successfully
  - Education, Training, Accountability
  - Controlled Management Processes ...

# 1&2. FM, UL/ULC Company Audit of Management System (MS)

- Employee Training & Education
- Systems Selection
- Communicate systems to Field
- Material Controls
- Systems installation “protocol”
- Labeling
- Record keeping - Variance Proce
- Non-Conformances
- Documentation
- Project closeout

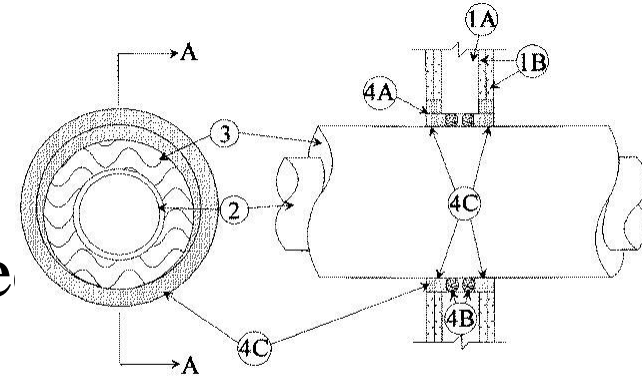

CONFIGURATION A

# 3. *Company MS Jobsite Audit* by **FM, UL/ULC**

- Verification of firestop systems Processes
- Verify Management System Works
- Verify Company “communication”
  - Office to field, field to office
- “Culture of Quality...”

»

Adler Photo





# 4. FM & UL Firestop Exam

## Company Appoints DRI if...

- **Pass Rigorous Firestop Examination**
  - FCIA Firestop Manual of Practice
  - Firestop Systems Selection & Protocol
  - Management System Knowledge
- Keep CEU's – 6 FM, 10 UL, ea. 3 yrs.
- Retested every 3 years *if CEU's not maintained*
- One DRI per FM/UL Contractor Location



# 5. Annual Audit

## FM 4991 UL / ULC

- Continued satisfactory performance
  - Quality Manual Implementation
- Documented - Archived record keeping
- Employee Training Documentation
- Jobsite Visit
- DRI CEU Verification
- **Find Contractors @ [www.fcia.org](http://www.fcia.org)**

# UL-ULC/FM 4991 Contractor Company Benefits

## **Quantified Differentiation ...**

- Focus on the **Company & Individual**
- Investment in Company Procedures
- Investment in People Education
- Investment in FCIA Manual of Practice
  - Project Successful Proven Contractor
  - Education, Training, Accountability
    - = Reduced Risk – Life, Property, Business



**Specified Technologies Inc.**  
**THE FIRESTOP AUTHORITY**

3530 33rd Way NW  
 Olympia, WA 98502-3223  
 p | 360.864.2722  
 f | 360.864.8184  
 m | 360.791.2915  
 email [info@stitec.com](mailto:info@stitec.com)  
 website [www.stitec.com](http://www.stitec.com)

Wednesday, February 10, 2010

Mr. Randy Perry  
 Adler Firestopping Ltd.  
 #23, 53016 Hwy 60  
 Acheson, AB T5T 1M9  
 Canada

Re: Qualified Firestop Applicator

As the firestop manufacturer with more UL and ULC Classified Firestop System Coverage than any other, we are intimately familiar with UL and ULC's QFC Program. We recognize the program as one of two best-in-class, third-party, quality assurance methods available to building project decision-makers to help ensure applicator quality. As such, we fully endorse the program and those applicators that have invested heavily to earn their way to become a member in this elite group of professionals.

It is our understanding that Adler Firestopping Ltd. is a ULC (Underwriters Laboratories of Canada) Qualified Firestop Contractor (QFC) in good standing. This can be verified at the bottom of the page at the following link:

<http://www.ul.com/global/eng/pages/offering/industries/buildingmaterials/qualifiedcontractorprogram/qualified/firestop/>

Moreover, Randy Perry has successfully attended our intensive, two-day FIT Level II program, taken the exam, earned a passing score and is within the two-year expiry period before renewal will be required. A copy of his certificate can be made available upon request.

Regards,

John Hurley  
 Regional Manager, Western US and Canada



**Underwriters  
 Laboratories**

Certificate Number: 1016

**QUALIFIED FIRESTOP CONTRACTOR CERTIFICATE**

Company Name: Adler Firestopping Ltd. File number: NC10757 Issued: 2/1/2010  
 Expires: 2/1/2011  
 Address: Edmonton Office, #23, 53016 Hwy 60, Acheson, AB, T7X 5A7, CANADA  
 Telephone #: (780)-962-9495 Fax #: (780)-962-9794 Email Address: randy@adlerfirestopping.com

This company has demonstrated that it complies with UL's Qualified Firestop Contractor Program Requirements for Canada. Under this programme, the Contractor has demonstrated knowledge of selection and installation of firestop systems as evidenced by the successful performance in a written examination by a "Designated Responsible Individual" (DRI). The Contractor has also established a Management System specifically focused on the proper selection and installation of ULC Listed Firestop Systems.

This certificate is not transferable and expires one (1) year after the issue date. This certificate may be displayed, copied and shared with others but must be used in its entirety. Only those companies listed in ULC's Online Certifications Directory for the Qualified Firestop Contractor Program at [www.ulc.ca/contractor](http://www.ulc.ca/contractor) are considered eligible for this program and to use this Certificate and the ULC marking (shown here) in its advertising and promotional material in accordance with the marking guidelines provided with this Certificate.



**Underwriters'  
 Laboratories of Canada,**  
LABORATOIRES DES ASSURÉS DU CANADA  
**Qualified Firestop  
 Contractor Program**

Underwriters Laboratories of Canada® reserves the right to void this certificate at any point. This certificate does not indicate compliance with any ULC Product Certification Program. For additional information regarding the Qualified Firestop Contractor Program, please visit [www.ulc.ca/contractor](http://www.ulc.ca/contractor).

Copyright© 2007 Underwriters Laboratories of Canada®



**FIRESTOP CONTRACTORS INTERNATIONAL ASSOCIATION**  
**Membership Certificate**

This certifies that  
**Adler Firestopping, Ltd.**  
 Edmonton, Alberta

is a Firestop Contractor Voting Member of the  
 Firestop Contractors International Association  
 and pledges to further the mission of FCIA.

**Robert N. LeClair, Jr., President, FCIA**

Don Murphy, *Vice President*  
 Don Sabrsula, *Secretary*  
 Scott Rankin, *Treasurer*  
 Randall Bosscawen, *Director*  
 Mike Dominguez, *Director*  
 Aedan Gleeson, *Director*  
 Bob Hastings, *Director*

# I – Inspection Systems Analysis

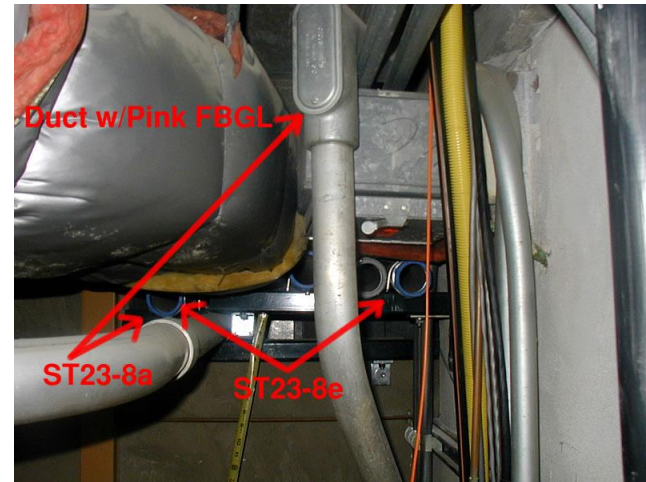

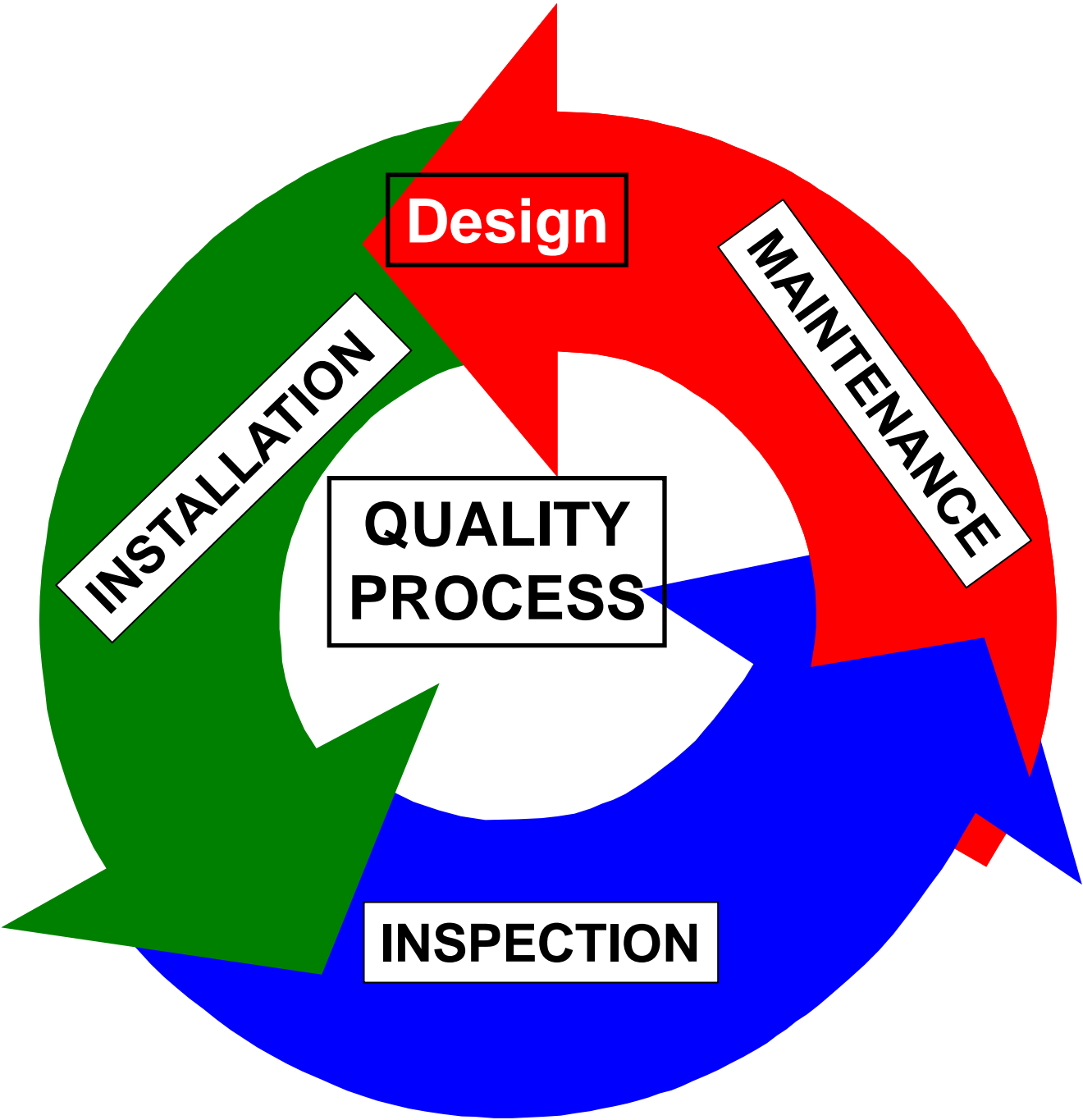

**Design**

**MAINTENANCE**

**QUALITY  
PROCESS**

**INSPECTION**

**INSTALLATION**

# Firestop Installation & Inspection

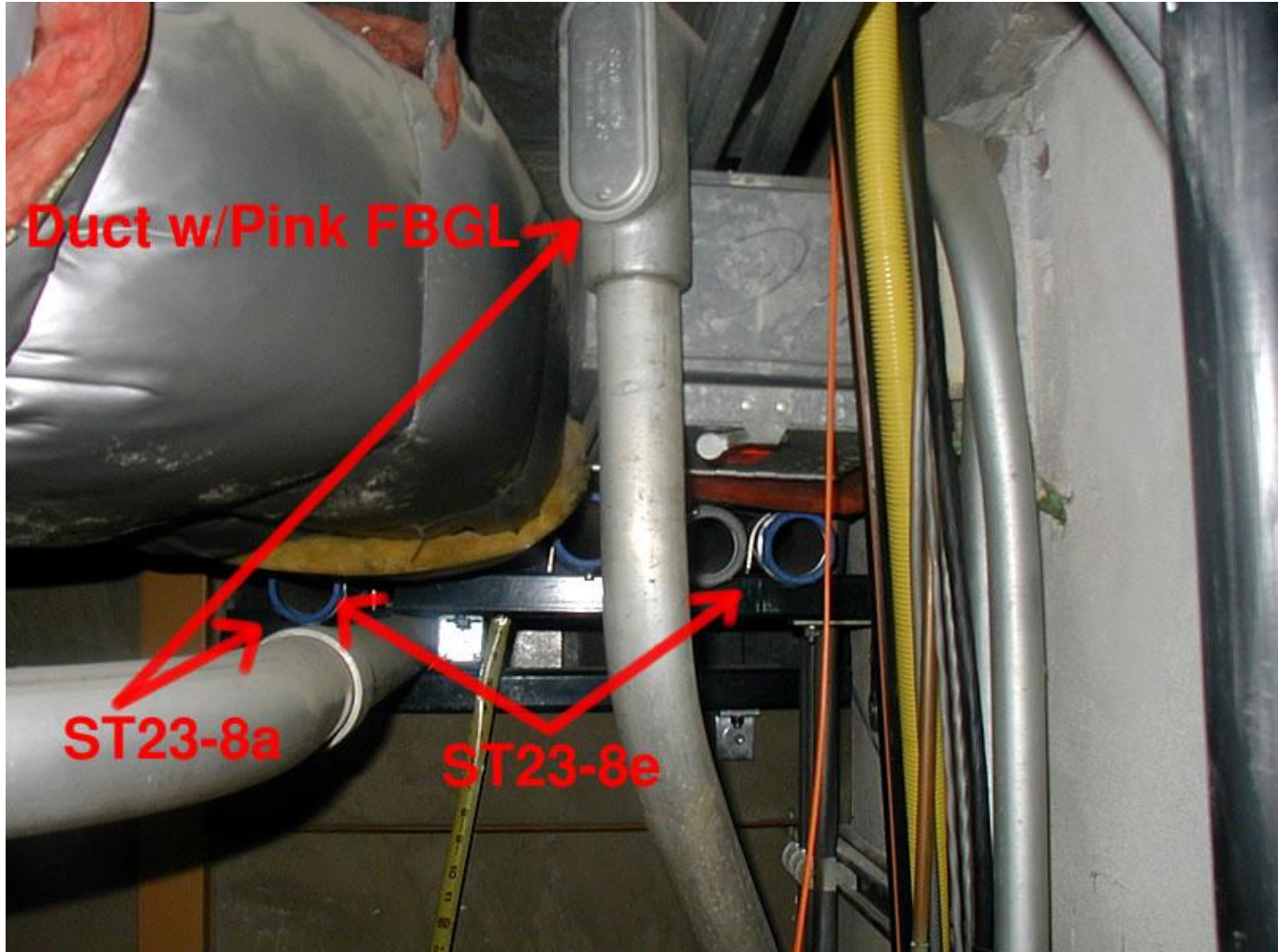

# Firestop Installation & Inspection

- ASTM E 2174/ ASTM E 2393 –





# I – Inspection Types

- **Contractor Self Inspection**
  - Verify Management System validity
  - Not 2%, 10%
  - Required for FM & UL, ULC Contractors
- **Manufacturer Inspection**
  - Recommends Independent Inspection
- **ASTM E 2174 & ASTM E 2393 –**
  - Independent 3<sup>rd</sup> Party
  - Destructive, Non Destructive
  - Specified Frequency

# I – Inspection – Code Requirements

## SECTION 104 –

### DUTIES AND POWERS OF BUILDING OFFICIAL

**104.1 General.** The *building official* is hereby authorized and directed to enforce the provisions of this code. The *building official* shall have the authority to render interpretations of this code and to adopt policies and procedures in order to clarify the application of its provisions. **Such interpretations, policies and procedures shall be in compliance with the intent and purpose of this code.** Such policies and procedures shall **not have the effect of waiving requirements** specifically provided for in this code. [IBC 2015, 104.1 ]

# I – Inspection – Code Requirements

**[A] 104.4 Inspections.** The *building official* shall make all of the required inspections, **or the *building official* shall have the authority to accept reports of inspection by *approved agencies* or individuals.** Reports of such inspections shall be in writing and be certified by a responsible officer of such *approved agency* or by the responsible individual. The *building official* is authorized to engage such expert opinion as deemed necessary to report upon unusual technical issues that arise, subject to the approval of the appointing authority.

**[IBC 2015 104.4]**

# I – Inspection – Code Requirements

**[A] 110.3 Required inspections.** The *building official*, upon notification, shall make the inspections set forth in Sections 110.3.1 through 110.3.10.

**[A] 110.3.6 Fire- and smoke-resistant penetrations.** Protection of joints and penetrations in fire-resistance rated assemblies, *smoke barriers* and smoke partitions shall not be concealed from view until inspected and *approved*.

**[IBC 2015, 110.3, 110.3.6 ]**

# I – Inspection – Code Requirements

**[A] 110.4 Inspection agencies.** The *building official* is authorized to accept reports of *approved* inspection agencies, provided such agencies satisfy the requirements as to qualifications and reliability. **[IBC 2015,110.4]**

**[A] 110.6 Approval required.** Work shall not be done beyond the point indicated in each successive inspection without first obtaining the approval of the *building official*....More. **[IBC 2015 110.6]**

# I – Inspection – Code Requirements

## Definitions

**APPROVED AGENCY.** An **established and recognized agency** regularly engaged in conducting tests or furnishing inspection services, when such agency has been *approved*.

**[IBC 2015, 202.2 Definitions]**

**APPROVED.** Acceptable to the *building official* or authority having jurisdiction.

**[IBC 2015, 202.2 Definitions]**

# I – Inspection – Code Requirements

**SPECIAL INSPECTOR.** A qualified person **employed or retained by an *approved* agency** and *approved* by the *building official* as having the competence necessary to inspect a particular type of construction requiring *special inspection*.

**[IBC 2015, 202.2 Definitions]**

# I – Inspection – Code Requirements

## **SECTION 1703 APPROVALS**

**1703.1 Approved agency.** *An approved agency shall provide all information as necessary for the building official to determine that the agency meets the applicable requirements. [IBC 2015, 1703.1 ]*



# I – Inspection – Code Requirements

**1703.1.1 Independence.** An approved agency shall be objective, competent and independent from the contractor responsible for the work being inspected. The agency shall also disclose possible conflicts of interest so that objectivity can be confirmed. **[IBC 2015, 1703.1.2]**

**1703.1.2 Equipment.** An approved agency shall have adequate equipment to perform required tests. The equipment shall be periodically calibrated.  
**[IBC 2015, 1703.1.2]**

# I – Inspection – Code Requirements

**1703.1.3 Personnel.** An approved agency shall employ experienced personnel educated in conducting, supervising and evaluating tests and/or inspections.

**[IBC 2015, 1703.1.3]**

# I – Inspection – Code Requirements

**1704.2 Special inspections.** Where application is made for construction as described in this section, **the owner or the registered design professional in responsible charge acting as the owner’s agent** shall employ one or more approved agencies to perform inspections during construction on the types of work listed under Section 1705. **These inspections are in addition to the inspections identified in Section 110.**

**[IBC 2015, 1704.2]**

# I – Inspection – Code Requirements

**1704.2.1 Special inspector qualifications.** The special inspector shall provide written documentation to the building official **demonstrating his or her competence** and relevant experience or training. **Experience or training shall be considered relevant** when the documented experience or **training is related in complexity to the same type of special inspection activities for projects of similar complexity and material qualities.** These qualifications are in addition to qualifications specified in other sections of this code. The **registered design professional in responsible charge** and engineers of record involved in the design of the project **are permitted to act as the approved agency and their personnel are permitted to act as the special inspector for the work designed by them, provided they qualify as special inspectors.**

**[IBC 2015, 1704.2.1 ]**

# I – Inspection – Code Requirements

**1705.16 Fire-resistant penetrations and joints.** In high-rise buildings or in buildings assigned to Risk Category III or IV in accordance with Section 1604.5, special inspections for through-penetrations, membrane penetration firestops, fire resistant joint systems, and perimeter fire barrier systems that are tested and listed in accordance with Sections 714.3.1.2, 714.4.1.2, 715.3 and 715.4 shall be in accordance with Section 1705.16.1 or 1705.16.2. [**IBC 2015, 1705.16** ]

# I – Inspection – Code Requirements

- **1705.1.1 Special cases.** Special inspections shall be required for proposed work that is, in the opinion of the building official, unusual in its nature, such as, but not limited to, the following **examples:**

# I – Inspection – Code Requirements

- Examples:
  - Construction materials and systems that are alternatives to materials and systems prescribed by this code. [EJ's]
  - Unusual design applications of materials described in this code. [EJ's]
  - Materials and systems required to be installed in accordance with additional manufacturer's instructions that prescribe requirements not contained in this code or in standards referenced by this code. [**IBC 2015, 1705.1.1** ]

# I – Inspection –

## Code Requirements

**HIGH-RISE BUILDING.** A building with an occupied floor located more than 75 feet (22 860 mm) above the lowest level of fire department vehicle access. [IBC 2015,202.2]



# I – Inspection – Code Requirements

**1705.16.1 Penetration firestops.** Inspections of penetration firestop systems that are tested and listed in accordance with Sections 714.3.1.2 and 714.4.1.2 shall be conducted by an approved inspection agency in accordance with ASTM E 2174.

**1705.16.2 Fire-resistant joint systems.** Inspection of fire resistant joint systems that are tested and listed in accordance with Sections 715.3 and 715.4 shall be conducted by an approved inspection agency in accordance with ASTM E 2393.

**[IBC 2015, 1705.16.2, 1705.16.3 ]**

# Firestop Systems Inspection

## ASTM E 2174 - ASTM E 2393

- ***“Standard Practice for On-Site Inspection of Installed Firestops***
  - Breaches by Penetrations (2174) and Joints (2393)
  - Standard Inspection Procedure
  - Inspection Agency Companies
  - Report to Contractor, Building Owner, (Authorizing Agency)

# Inspection in Codes

## ASTM E 2174 - ASTM E 2393

- NFPA 101 / 5000 - Chapter 8 - Annex
- 2012 International Building Code
  - CH 1705.16 – Special Inspections
    - Buildings 75' & higher above Fire Department Access
    - Occupancy Type III, IV, Chapter 16 Table 1604.5
- Abu Dhabi International Building Code

# Inspection - Qualifications

## ASTM E 2174 - ASTM E 2393

- **Inspector Firm & Inspectors**

- **‘Independent of, and Divested from ’**  
Installing firm, Distributor, Manufacturer,  
Competitor, Supplier...
- **‘Not a Competitor** of the Installer, contractor,  
manufacturer, or supplier ....
- **Submit notarized statements of ...**

# Inspection - Qualifications

## ASTM E 2174 - ASTM E 2393

- Inspector **Personnel** meet at least one criteria.....
  - 2 years experience (Construction, Field), education, and credentials acceptable to AHJ
  - Accredited by AHJ
  - Meet ASTM E699
  - ~~– Accredited by AHJ~~
  - ~~– Meet ASTM E699~~
- **Inspection Agency Company Qualification - AC 291 – W/Individual Certs.**

# Inspection – Company Qualifications

- **ASTM E 329**
- **IAS AC 291**

**Management System Based**

**Independent Audits**

**Both with Individual Verification of Knowledge.**

# Inspection - Qualifications

## IAS AC 291 Accreditation

- Inspection Firm shall have at least one ...
  - PASS UL or FM Firestop Exam
  - 1 year Quality Assurance
  - Or...*
  - PASS UL/FM Firestop Exam, *and* PE, FPE, Registered Architect, or
  - PASS UL/FM Firestop Exam, *and* Education by Certified Agency

# IAS AC 291 Accredited Inspection Agencies

- **Specify IAS AC 291 –**
  - Quantified Qualifications
  - Helps AHJ with “Approved Agency”
  - Not in ASTM Standards, Code
- **Specify Individual Certifications**
  - 3<sup>rd</sup> Party, Independent Exams verify Knowledge
    - FM Firestop Exam
    - UL Firestop Exam



# Inspection Process

## ASTM E 2174 - ASTM E 2393

- Pre Construction Meeting
  - Review Documents – Identify Conflicts
  - Review Materials – SYSTEMS
    - **ASTM E 814 or UL 1479, FM 4990, ASTM E 1966, UL 2079, ASTM E 2307 Systems, ULC S-115**
- Inspection Documents
  - Manufacturer Product Data Sheets
  - Tested and Listed Systems & EJ's
  - Safety Data Sheets

# Inspection Process

## ASTM E 2174 - ASTM E 2393

- Pre-Construction Meeting
  - Mock Ups
  - Destructive Testing
  - Installation Measurements
  - Discuss Inspection Method
- Meeting Required
  - During/Post Inspection Methods

# Inspection Methods

## ASTM E 2174 - ASTM E 2393

- During Construction
  - Random witness, Each Floor
    - **10%, each type** of Penetration Firestop,
    - **5% of Total Lineal Feet** of Fire Resistance Rated Joint System, each type



Adler Photo

# Inspection Methods

## ASTM E 2174 - ASTM E 2393

- Post Construction - Destructive Testing
  - **Minimum 2% , no less** than 1, each type per 10,000 SF of floor area
  - **Minimum 1 / 500 LF** of Joint Area, mandatory
  - If 10% variance per firestop type
    - Inspection stops
    - Installer inspects, repairs
    - Inspector reinspects



# Inspection Methods

## ASTM E 2174 - ASTM E 2393

- Variances....
  - ASTM E 2174 & ASTM E 2393
    - One Day Notice after discovery to Contractor
  - International Building Code 1704.2.4
    - ‘Brought to IMMEDIATE attention of contractor’
    - ‘If not corrected, Building Official AND RDP... notified prior to completion of that phase’



# Inspection Methods

## ASTM E 2174 - ASTM E 2393

- Both Methods...
  - If 10% variance per firestop type
    - Inspection stops
    - Installer inspects, repairs
    - Inspector reinspects
  - ***Inspector Shall not Supervise Workers...***
  - Inspect @ Firestop Installation Start

# Inspection Forms

## ASTM E 2174 - ASTM E 2393

- One for each type of firestop
- Submit 1 day after Inspection to  
Authorizing Agency
- Numbered – Controlled
- Required – During/Post Construction  
Methods

# Inspection Reports - IBC

**1704.2.4 Report requirement.** Special inspectors shall keep records of inspections. The special inspector shall furnish inspection reports to the building official, and to the registered design professional in responsible charge. Reports shall indicate that work inspected was or was not completed in conformance to approved construction documents.

**Discrepancies shall be brought to the immediate attention of the contractor for correction.** If they are **not corrected**, the discrepancies shall be brought to the attention of the building official and to the registered design professional in responsible charge **prior to the completion of that phase of the work.** A final report documenting required special inspections and correction of any discrepancies noted in the inspections shall be submitted at a point in time agreed upon prior to the start of work by the applicant and the building official.



# Inspection Final Report

## ASTM E 2174 - ASTM E 2393

- Name, address, location – project, installer, inspector
- Type and quantity of firestops inspected
- Verification method
- Percentage Deviation
- Copies of all documents sent to Authorizing Agency

CUL SYSTEM NO. C-AJ-2022  
**PLASTIC PIPE THROUGH CONCRETE FLOOR/WALL OR BLOCK WALL ASSEMBLY**  
 F-RATING = 2-HR.  
 FT, FH AND FTH-RATING = 0-HR.

NOTE: TESTED WITH A 50 P.S.I. PRESSURE DIFFERENTIAL

TOP VIEW SECTION A-A

1. CONCRETE FLOOR OR WALL ASSEMBLY (2-HR. FIRE-RATING):  
 A. LIGHTWEIGHT OR NORMAL WEIGHT CONCRETE FLOOR OR WALL (MIN. 2-1/2" THICK).  
 B. ANY UL/CUL CLASSIFIED CONCRETE BLOCK WALL.

2. PENETRATING ITEM TO BE ONE OF THE FOLLOWING:  
 A. MAXIMUM 4" NOMINAL DIAMETER PVC PLASTIC PIPE (CELLULAR OR SOLID CORE),  
 B. MAXIMUM 4" NOMINAL DIAMETER ABS PLASTIC PIPE (CELLULAR OR SOLID CORE),  
 C. MAXIMUM 4" NOMINAL DIAMETER FRPP PLASTIC PIPE,  
 D. MAXIMUM 4" NOMINAL DIAMETER CPVC PLASTIC PIPE (SDR 13.5) (CLOSED PIPING SYSTEM ONLY),  
 E. MAXIMUM 3" NOMINAL DIAMETER AQUARISE CPVC PLASTIC PIPE (SDR 11) MANUFACTURED BY IPEX, INC. (CLOSED PIPING SYSTEM ONLY),  
 F. MAXIMUM 4" NOMINAL DIAMETER RIGID NONMETALLIC CONDUIT (SCH 40 PVC).

3. HILTI CP 648E WRAP STRIP (NOMINAL 3/16" THICK x 1-3/4" WIDE) WRAPPED CONTINUOUSLY AROUND THE OUTER CIRCUMFERENCE OF PIPE, AS SPECIFIED IN THE TABLE BELOW, WITH ENDS BUTTED AND HELD IN PLACE WITH TAPE. WRAP STRIP TO BE INSERTED INTO ANNULAR SPACE AND POSITIONED 1/4" FROM BOTTOM SURFACE OF CONCRETE FLOOR.

4. MINIMUM 1/4" DEPTH HILTI FS-ONE INTUMESCENT FIRESTOP SEALANT.

MAXIMUM PIPE DIAMETER	MAXIMUM DIAMETER OF OPENING	ANNULAR SPACE		NO. OF HILTI CP 648E WRAP STRIPS
		MINIMUM	MAXIMUM	
2"	3-1/2"	3/16"	7/8"	1
3"	5"	3/8"	1-1/8"	2
4"	6"	3/8"	1-1/8"	2

NOTES: 1. HILTI CP 648E WRAP STRIPS AND HILTI FS-ONE INTUMESCENT FIRESTOP SEALANT ARE REQUIRED ON BOTH SIDES OF A WALL ASSEMBLY.  
 2. CLOSED OR VENTED PIPING SYSTEM (PVC, ABS, FRPP = SCH 40; CPVC = SDR 11 OR 13.5).

# Firestopping & Compartmentation for Safety

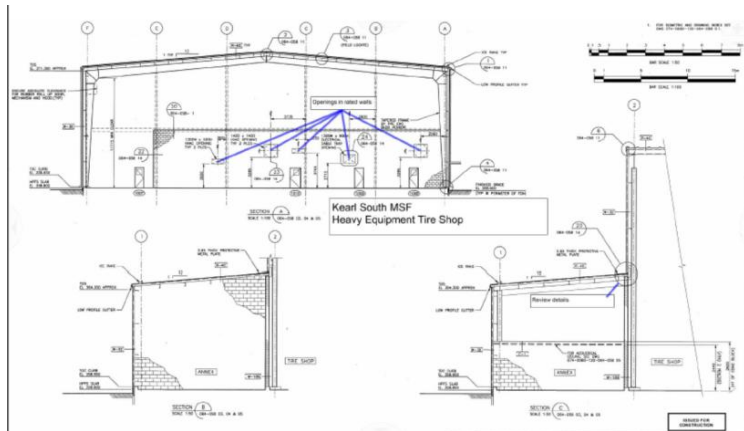
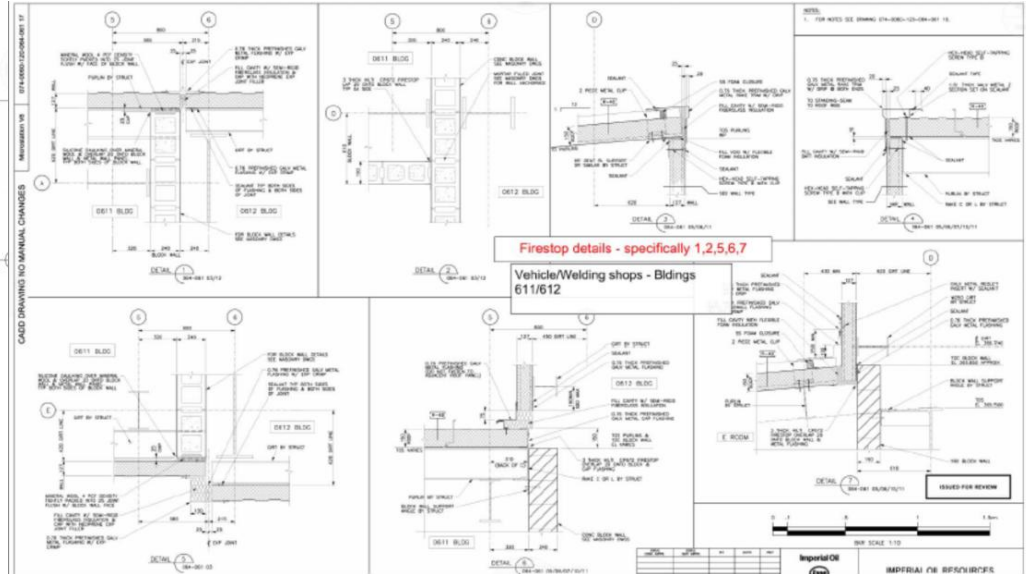
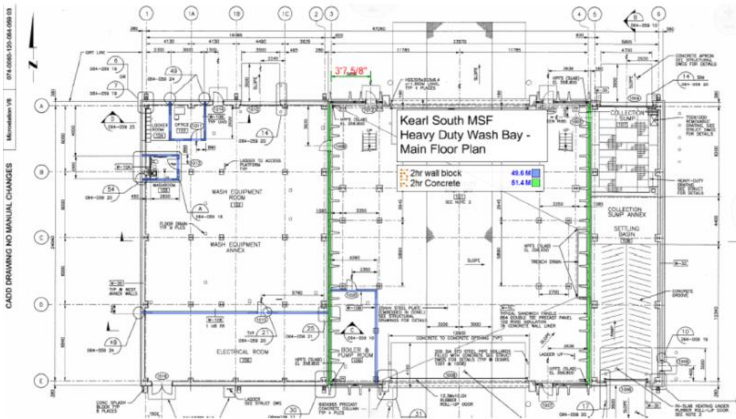

# Firestopping & Compartmentation for Safety

- Inspection Agency
  - Copies of all documents sent to Authorizing Agency
- Firestop Contractor
  - Product Data Sheets & Installation Instructions
  - ‘SYSTEMS’, Fire Resistance-Rated Assemblies As Built
  - Inspection Documents
  - Warranty Documents
  - Maintenance Requirements
  - Certificate of Compliance to Specs
  - FCIA Member in Good Standing Certificate

CUL SYSTEM NO. C-AJ-2022  
 FIRE-RATING = 2-HR.  
 FT, FH AND FTH-RATING = 6-HR.  
 NOTE : TESTED WITH A 50 Ps PRESSURE DIFFERENTIAL

PLASTIC PIPE THROUGH CONCRETE FLOOR/WALL OR BLOCK WALL ASSEMBLY

1. CONCRETE FLOOR OR WALL ASSEMBLY (2-HR, FIRE-RATING) :  
 A. LIGHTWEIGHT OR NORMAL WEIGHT CONCRETE FLOOR OR WALL (MIN. 2-1/2" THICK).  
 B. ANY UL-LISTED CLASSIFIED CONCRETE BLOCK WALL.

2. PENETRATING ITEM TO BE ONE OF THE FOLLOWING :  
 A. MAXIMUM 4" NOMINAL DIAMETER PVC PLASTIC PIPE (CELLULAR OR SOLID CORE).  
 B. MAXIMUM 4" NOMINAL DIAMETER ABS PLASTIC PIPE (CELLULAR OR SOLID CORE).  
 C. MAXIMUM 4" NOMINAL DIAMETER FRPP PLASTIC PIPE.  
 D. MAXIMUM 4" NOMINAL DIAMETER CPVC PLASTIC PIPE (SDR 13.5) (CLOSED PIPING SYSTEM ONLY).  
 E. MAXIMUM 2" NOMINAL DIAMETER AQUARIUM CPVC PLASTIC PIPE (SDR 11) MANUFACTURED BY IPEX, INC. (CLOSED PIPING SYSTEM ONLY).  
 F. MAXIMUM 4" NOMINAL DIAMETER RIGID NONMETALLIC CONDUIT (SCH 40 PVC).  
 H. HILTI CP 648E WRAP STRIP (NOMINAL 3/16" THICK x 1-3/4" WIDE) WRAPPED CONTINUOUSLY AROUND THE OUTER CIRCUMFERENCE OF PIPE, AS SPECIFIED IN THE TABLE BELOW, WITH ENDS BUTTED AND HELD IN PLACE WITH TAPE. WRAP STRIP TO BE INSERTED INTO ANNULAR SPACE AND POSITIONED 1/4" FROM BOTTOM SURFACE OF CONCRETE FLOOR.

3. MINIMUM 1/4" DEPTH HILTI FS-ONE INTUMESCENT FIRESTOP SEALANT.

MAXIMUM PIPE DIAMETER	MAXIMUM DIAMETER OF OPENING	ANNULAR SPACE		NO. OF HILTI CP 648E WRAP STRIPS
		MINIMUM	MAXIMUM	
2"	3-1/2"	3/16"	7/8"	1
3"	5"	3/8"	1-1/8"	2
4"	6"	3/8"	1-1/8"	2

NOTES : 1. HILTI CP 648E WRAP STRIP(S) AND HILTI FS-ONE INTUMESCENT FIRESTOP SEALANT ARE REQUIRED ON BOTH SIDES OF A WALL ASSEMBLY.  
 2. CLOSED OR VENTED PIPING SYSTEM (PVC, ABS, FRPP = SCH 40; CPVC = SDR 11 OR 13.5).

# Why Specify Inspection?

- **DIIM – ‘II’** of Quality Process
  - Install, **Inspect**
- Verify Field Installations
- **Specify Accredited Inspection Agencies**
  - IAS AC 291 – Accreditation Criteria for Special Inspection Agencies
- **Individuals Educated & Trained**
  - **3<sup>rd</sup> Party Exam, Approved Source**
  - **FM or UL Firestop Exam**

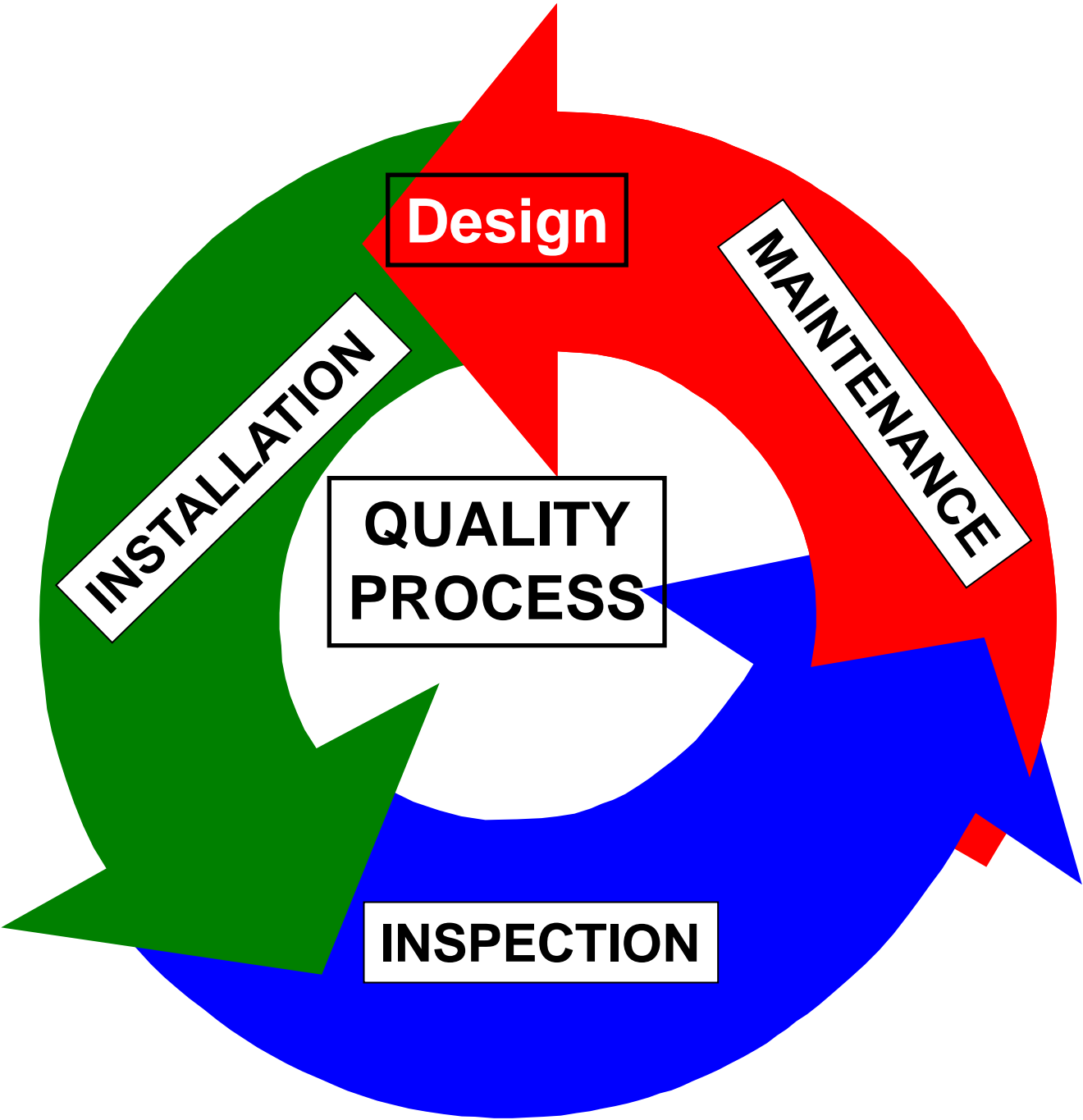

# 07-84-00 Specifications (FREE @ FCIA.org)

## **MasterFormat - 07 84 00 - Firestopping**

- **Part I** – FCIA Member, FM 4991 Approved or UL Qualified Firestop Installer/Contractor - Valid DRI, Test Standards
- **Part II – Firestop Products** – Testing, Physical Properties to protect breaches in fire resistance-rated and smoke resistant...
  - Penetrations & Fire Resistance Rated Joints –
  - Perimeter Fire Containment Joints
- **Part III, Execution, Quality Assurance (DIV 1 Reference)**
  - **ASTM E 2174 & ASTM E 2393 Inspection**
  - **IAS AC 291 Accredited Inspection Agency**
    - Individual on staff passed FM or UL Firestop Exam

# 07-84-00 Specifications

- **Systems Testing – Part 1 – DIIM References**
  - Penetrations - ASTM E 814 & UL 1479
  - Joints - ASTM E 1966, UL 2079, S115
  - Perimeter - ASTM E 2307
  - FM 4991 Standard for the Approval of Firestop Contractors
  - UL – ULC Qualified Firestop Contractor Program
  - ASTM E 2174 & ASTM E 2393 - Inspections
  - IAS AC 291 Accredited Inspection Agency

# 07-84-00 Specifications

- **Single Source Product??**
- **YES...**
  - ‘...to the greatest extent possible.’
  - Number of Systems v. EJ’s
  - IFC Protocol for EJ’s
    - ***No EJ-EFRRRA if Tested/Listed System Available***



# 07-84-00 Specifications

- **Scope is About Firestop Systems**
  - “F” Ratings - Fire Resistance-Rated Assy.
  - “T” Ratings - = Equal to Assy. Rating
  - “H” Ratings – Hose Stream
  - “L” Ratings = Smoke Resistance
  - “W” Ratings – Floors, Walls
- **Firestop Materials & Physical Property Requirements – Resistance to...**
  - Chemicals, Movement, Exposure

# M – Maintenance (& Management)

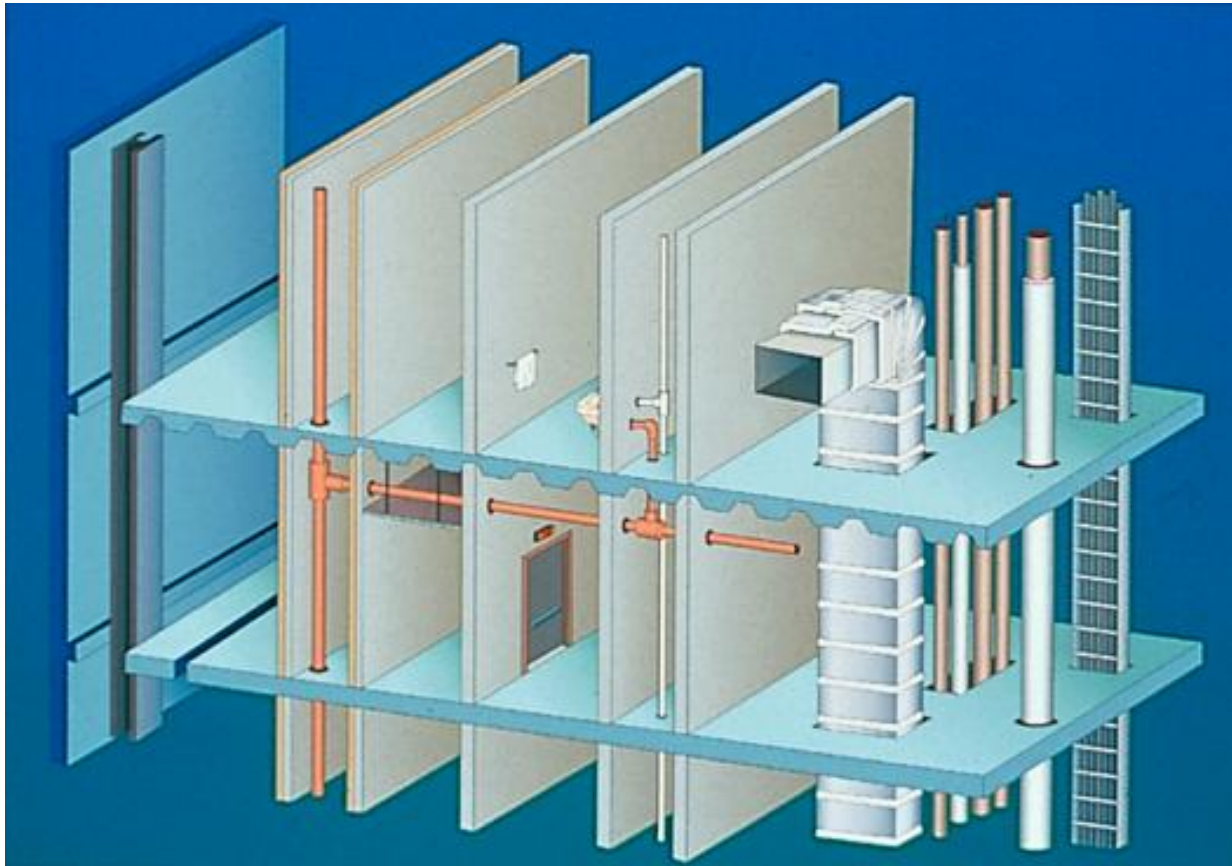

# Firestop Maintenance

- **Maintenance**
  - Code Required
  - How??
- **How to keep Track – Barrier Management Initiatives**
  - Paper
  - Software
  - Labeling



# National Fire Protection Association - NFPA 101-2012

- **SECTION 4.5.8 Maintenance, Inspection, and Testing.**
- **4.5.8.1 Whenever or wherever any device**, equipment, system, condition, arrangement, level of protection, fire-resistive construction, or any other feature **is required for compliance** with the provisions of this Code, **such device**, equipment, system, condition, arrangement, level of protection, fire-resistive construction, or other feature **shall thereafter be continuously maintained** in accordance with applicable NFPA requirements or requirements developed as part of a performance-based design, or as directed by the AHJ. [NFPA 101-2012:4.6.12.1]

# National Fire Protection Association - NFPA 101-2012

- **4.5.8.2** No existing life safety feature shall be removed or reduced where such feature is a requirement for new construction. [101:4.6.12.2]
- **4.5.8.3\*** Existing life safety features **obvious to the public**, if not required by the Code, shall be either maintained or removed. [101:4.6.12.3]
- **4.5.8.4** Any device, equipment, system, condition, arrangement, level of protection, fire-resistive construction, or any other feature **requiring periodic testing, inspection, or operation** to ensure its maintenance shall be tested, inspected, or operated as specified elsewhere in this Code or as directed by the AHJ. [101:4.6.12.4]
- **4.5.8.5** Maintenance, inspection, and testing shall be performed under the supervision of a responsible person who shall ensure that testing, inspection, and maintenance are made at specified intervals in accordance with applicable NFPA standards or as directed by the AHJ. [NFPA 101-2012:4.6.12.5]

# International Fire Code Maintenance

## SECTION 703

### FIRE-RESISTANCE-RATED CONSTRUCTION

**703.1 Maintenance.** The required *fire-resistance rating* of fire-resistance-rated construction, including, but not limited to, walls, firestops, shaft enclosures, partitions, *smoke barriers*, floors, fire-resistive coatings and sprayed fire-resistant materials applied to structural members and fire-resistant joint systems, shall be maintained. Such elements **shall be visually inspected by the *owner* annually and properly repaired, restored or replaced where damaged, altered, breached or penetrated. Records of inspections and repairs shall be maintained..**



# International Fire Code Maintenance

## SECTION 703

### FIRE-RESISTANCE-RATED CONSTRUCTION

**703.1 Maintenance. (continued)** Where concealed, such elements shall not be required to be visually inspected by the *owner* unless the concealed space is accessible by the removal or movement of a panel, access door, ceiling tile or similar movable entry to the space. Openings made therein for the passage of pipes, electrical conduit, wires, ducts, air transfer openings and holes made for any reason **shall be protected with *approved* methods** capable of resisting the passage of smoke and fire. Openings through fire-resistance-rated assemblies shall be protected by self- or automatic-closing doors of *approved* construction meeting the fire protection requirements for the assembly.



# International Fire Code Maintenance

## SECTION 703

### FIRE-RESISTANCE-RATED CONSTRUCTION

#### 703.1 Maintenance. (continued) 703.1.1 Fireblocking and draftstopping.

Required *Fireblocking* and draftstopping in combustible concealed spaces shall be maintained to provide continuity and integrity of the construction.

**703.1.2 Smoke barriers and smoke partitions.** Required *smoke barriers* and smoke partitions shall be maintained to prevent the passage of smoke.

Openings protected with *approved* smoke barrier doors or smoke dampers shall be maintained in accordance with NFPA 105.

#### 703.1.3 Fire walls, fire barriers and fire partitions.

Required *fire walls, fire barriers* and *fire partitions* shall be maintained to prevent the passage of fire. Openings protected with *approved* doors or fire dampers shall be maintained in accordance with NFPA 80.





# UAE Fire and Life Safety Code of Practice

## Maintenance & Management

### Chapter 1, SECTION 21 Firestopping

21.15.2 The required fire resistance rating of installed firestop systems shall be ***visually inspected by the owner or owner's inspection agency annually.*** Damaged, altered or breached firestop systems shall be properly repaired, restored or replaced to comply with applicable codes as per the guidelines of Civil defense.

21.15.3 Any new **Openings** made therein for the passage of through penetrants, **shall be protected with approved firestop system** to comply with applicable codes as per the guidelines of Civil defense.

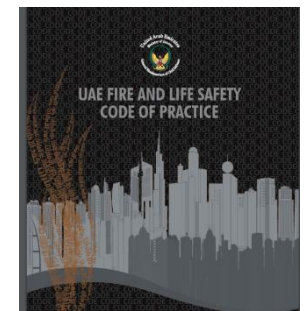

# National Fire Code of Canada

## National Fire Code of Canada

- ***Division B – Part 2, Building and Occupant Fire Safety***  
***2.2.1.2 – Damage to Fire Separations*** – where *fire separations* are damaged so as to affect their integrity, they shall be repaired so that the integrity of the *fire separation* is maintained...
- **FCIA Manual of Practice – Appendix, Maintenance, Marking & Identification Systems**  
FCIA recommends Barrier Management Systems and Identification/Marking Systems (Labels, Tags.) for Effective Compartmentation and Structural Protection



***Includes Fire Dampers, Fire Doors...and Continuity***

# “TOTAL FIRE PROTECTION”

- Effective Compartmentation
  - Fire Barriers, Fire Walls/Floors, Smoke Barriers
  - Firestopping, Fire Dampers, Swinging and Rolling Fire Doors, Fire Rated Glazing
- Detection & Alarm Systems
- Sprinkler Suppression Systems
- Education & Egress—
  - Building Owners & Managers, Building Occupants and Firefighters



# FCIA DIIM & Firestopping

Proper ***DCIIM*** Means Reliable Systems...

- **Properly *Designed*** - A/E - Consultant
  - Tested and Listed Systems, FCIA Member Mfr's., Compartments to IBC, NFPA, NBC, Local Codes, SUBMITTALS....*Specified (CCS, CDT, RSW)*
- **Properly *Coordinated & Installed***
  - **FCIA Member, FM 4991, or UL *Qualified Contractors***
- **Properly *Inspected***
  - ASTM E 2174 & ASTM E 2393,
  - *Inspectors, who Passed the FM or UL Firestop Exam, IFC*
  - *IAS AC 291 Accredited Inspection Firms*
- **Properly *Maintained & Managed*** –
  - FCIA Member, FM 4991, or UL-ULC Qualified Firms
  - Surveys by FCIA Member, FM, UL Qualified, IAS Accredited

# FCIA DIIM & Firestopping I & I - Inspection Webinar

- Free Subscription to Life Safety Digest
  - [info@FCIA.org](mailto:info@FCIA.org)
- Specifications
  - [info@FCIA.org](mailto:info@FCIA.org)

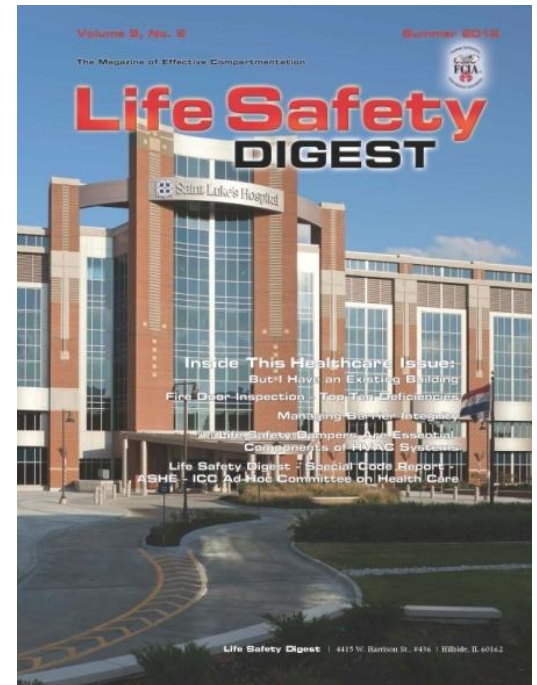

# Effective Compartmentation is a SYSTEM





# Contacts

Firestop Contractors International Association

Hillside, IL – +1-708-202-1108 - office

Bill McHugh – bill @ fcia.org

# FCIA's Webinar Series

## Inspection

08 June 2016

