

TGP

TECHNICAL GLASS PRODUCTS®
one source. many solutions.™

Fire-Rated Glazing & Framing



Presentation Overview

- Advancements in the materials and systems used for glazing in areas that require fire ratings
- Testing Methodologies
 - Furnace Test
 - Hose Stream Test
 - Impact Test
- Fire Protective vs. Fire Resistive
- Labeling - New Labeling System for Fire-Rated Glass
- Non-Code Compliant Products

Fire-Rated Glazing

Fire-Rated Glazing Definition

Specialized glass designed to prevent the spread of flames, gasses and smoke.

- Glass earns fire ratings through rigorous testing processes at independent laboratories such as Underwriters Laboratories, Inc.® (UL)
- Fire-rated glazing for door and window assemblies are rated from 20 minutes to 3 hours
- The rating reflects the amount of time the material has been tested to remain in place to help stop the spread of fire, smoke and gas
- In addition to remaining in place, in most cases the glass must also pass a hose stream test, and may also be required to provide an impact rating for safety

Fire-Rated Glazing

Fire-Rated Glazing Types



Wired Glass



Glass Ceramics



Transparent Walls

Fire-Rated Glazing

Key Purposes of Fire-Rated Glass

- Compartmentation
- Prevents fire from spreading
- Allows visibility into a space



Fire-Rated Glazing

Key Testing Components for Fire and Human Impact Safety

Fire Furnace Test - Measures the amount of time, in minutes or hours, that fire rated glazing and framing can withstand fire exposure in a furnace.

Hose Stream Test - Heated glass and frames are subjected to water from a fire hose. The cooling, impact and erosion created by the hose stream tests the integrity of the glass and frames and eliminates inadequate materials.

Impact Safety Test - Measures the ability of glass to withstand impact. Ratings are given in levels based on the amount of force the glass can resist. Typically defined by CPSC Category 1 or 2 rating.

Fire Test



Click on video to play

Hose Stream Test



Click on video to play

Safety Glazing Classifications

CPSC 16 CFR 1201 (Category II)

- 400 ft. lbs. pressure
- Tempered Glass, typical laminated glass, filmed glass

CPSC 16 CFR 1201 (Category I)

- 150 ft. lbs. pressure
- Permitted up to 1,296 in²

ANSI Z97.1 (Traditional Wired Glass Only)

- 100 ft. lbs. Pressure
- Permitted up to 1,296 in²



Impact Safety Test



Click on video to play

Types of Fire-Rated Glazing

FIRE PROTECTIVE

- Stop flames & smoke
- “Openings”
- “Thin” glazing
- Traditional fire-rated material (wired glass, glass ceramic, hollow metal steel frames, etc.)
- Fire Windows: 45-90 Minutes
- Fire Doors: 20 minutes – 3 hrs
- May not exceed 25% of the area of a common wall
- May not exceed 156 ft²
- May not exceed manufacturers tested sizes

NOTE: All products rated more than 20 min. have to pass hose stream test.



Types of Fire-Rated Glazing

FIRE RESISTIVE

- Stop flames, smoke, **AND** radiant heat (Both glass and frames)
- “Thick” glazing
- Subjected to Furnace and Hose Stream test, as well as impact
- Classified as a “wall” rather than an opening (window)
- Both glass and frames must block passage of radiant heat
- Classified as Wall Construction, and may be used in multi story spans or floor to ceiling sizes

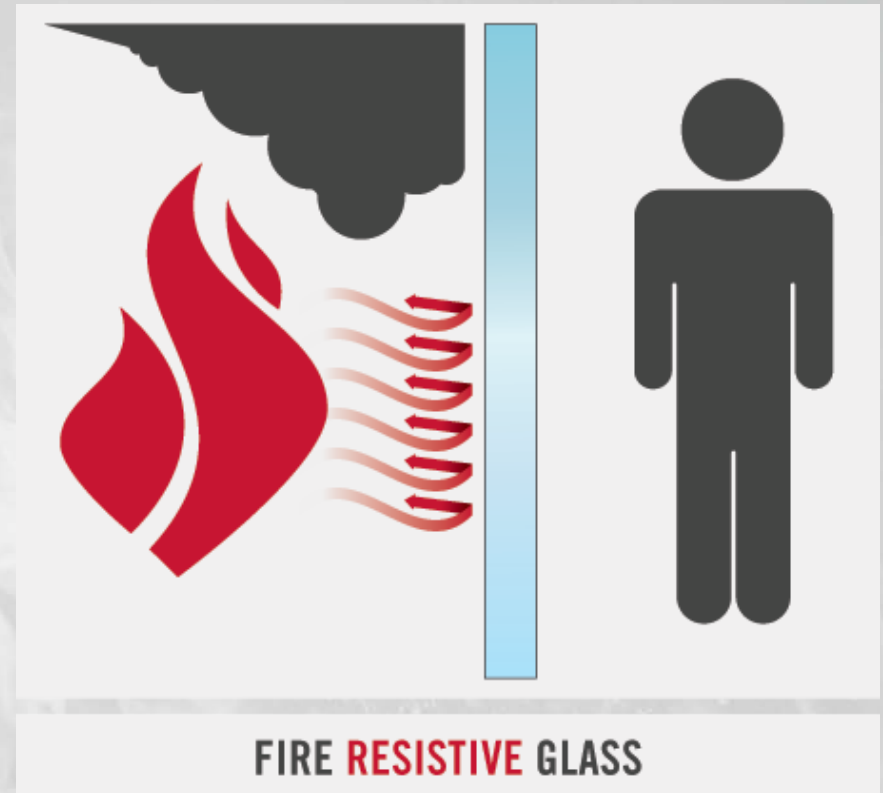

Labeling Requirements



Labeling Requirements

Why is Fire-Rated Glazing Labeled?

- Enables code officials to accurately inspect glazing
- Owner, architect, facility manager and installer can confirm they received correct product, and reject any materials that are not part of the tested and listed system, which would result in a non-compliant installation
- Fire Officials can plan safe evacuation methods
- Firefighters will understand the type of glass present in a building
- Ensure proper fire-rated glazing is installed in renovated spaces



Labeling Requirements

Fire-Rated Glass Manufacturer Label

FireLite[®]

**D-H-20
OH-20**



**6259
R-13377
ANSI/UL9/10B/10C**



**GLAZING MATERIALS
9FX5**

Pilkington Pyrostop
120-104
16 CFR 1201 CAT II
ANSI Z97.1-2009 UA
LAMINATED
W-120
North America
TGP

2" wide x .75" tall

Label Standards

Labeling Requirements

- “W” indicates that the glass passes ASTM E119
 - This is the wall standard which includes temperature rise and hose stream
- “D” indicates that the glass passed NFPA 252
 - Door standard
- “O” indicates that the glass passed NFPA 257
 - Opening standard
- “H” indicates that the glass passed hose stream test

**TABLE 716.3
MARKING FIRE-RATED GLAZING ASSEMBLIES**

FIRE TEST STANDARD	MARKING	DEFINITION OF MARKING
ASTM E 119 or UL 263	W	Meets wall assembly criteria.
NFPA 257 or UL 9	OH	Meets fire window assembly criteria including the hose stream test.
NFPA 252 or UL 10B or UL 10C	D	Meets fire door assembly criteria.
	H	Meets fire door assembly “Hose Stream” test.
	T	Meets 450°F temperature rise criteria for 30 minutes
	XXX	The time in minutes of the fire resistance or fire protection rating of the glazing assembly

For SI: °C = [(°F) - 32]/1.8.

Labeling Requirements

Fire-Rated Frame Manufacturer Label



Fireframes® Heat Barrier Series S
by TGP
SPECIAL PURPOSE FIRE DOOR FRAME ASSEMBLY
FIRE RATING 60 MIN. SERIAL NO _____
TEMPERATURE RISE, 30 MIN. 250° MAX
POSITIVE PRESSURE
ALSO CLASSIFIED IN ACCORDANCE WITH UL-10C

Installers should not remove or paint over frame labels



Fireframes® Designer Series S
by TGP
SPECIAL PURPOSE FIRE DOOR & WINDOW FRAME ASSEMBLIES
FIRE RATING 60 MIN. SERIAL NO _____
POSITIVE PRESSURE
ALSO CLASSIFIED IN ACCORDANCE WITH UL-10C

Labeling Requirements

UL Online Certifications Directory

- Available online at database.ul.com
- Search for UL File Number found on label for more information on listing

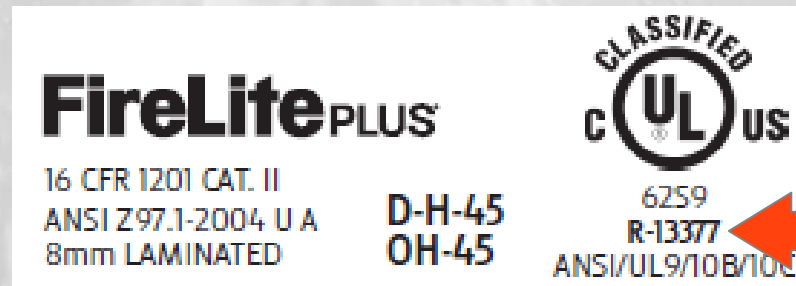

Labeling Requirements



BEGIN A BASIC SEARCH

To begin a search, please enter one or more search criteria in the parameters below.

Company Name ([options](#))

City

US State

US Zip Code

Country

Region

Postal Code (non-US)

UL Category Code ([options](#))

UL File Number ([help](#))

Keyword

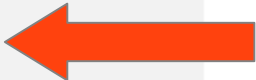

TIPS FOR EFFECTIVE SEARCHES

Select a search method

- Match all words - type AND between words (i.e., display **and** nwgq)
- Match any word - type OR between words (i.e., hair dryer **or** blow dryer)
- Match phrase(s) - type exact phrase

ABOUT THE ONLINE CERTIFICATIONS DIRECTORY

You can use the UL Online Certification Directory to:

- Verify a UL Listing, Classification, or Recognition
- Verify a UL Listed product use
- Verify a UL Recognized component use
- Verify a product safety standard

Learn more with the [Quick Guide to the Online Certifications Directory](#)

SPECIFIC SEARCHES (New! [UL Evaluation Reports](#))

Select a specific search:

FEATURED LINKS

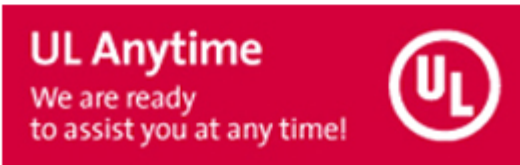
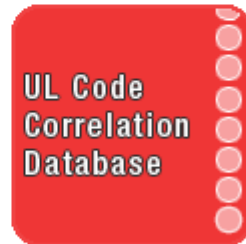

LINKS OF INTEREST

[UL Environment Database](#)

Labeling Requirements

Search results



ONLINE CERTIFICATIONS DIRECTORY [Home](#) [Quick Guide](#) [Contact Us](#) [UL.com](#)

Search results

You may choose to [Refine Your Search.](#)

Company Name	Category Name	Link to File
TECHNICAL GLASS PRODUCTS	Fire-protection-rated Glazing Materials	KCMZ.R13377
TECHNICAL GLASS PRODUCTS	Fire-protection-rated Glazing Materials Certified for Canada	KCMZ7.R13377

Model number information is not published for all product categories. If you require information about a specific model number, please contact [Customer Service](#) for further assistance.

[Search Tips](#) [Print this page](#) [Terms of Use](#) [iQ Family of Databases](#)

© 2013 UL LLC

[Listed System Example](#)

Installation of Fire-rated assemblies

- Framing similar to typical storefront systems
- Any qualified glazing subcontractor can install
- Must follow manufacturer's installation guidelines, as well as tested and listed design from UL

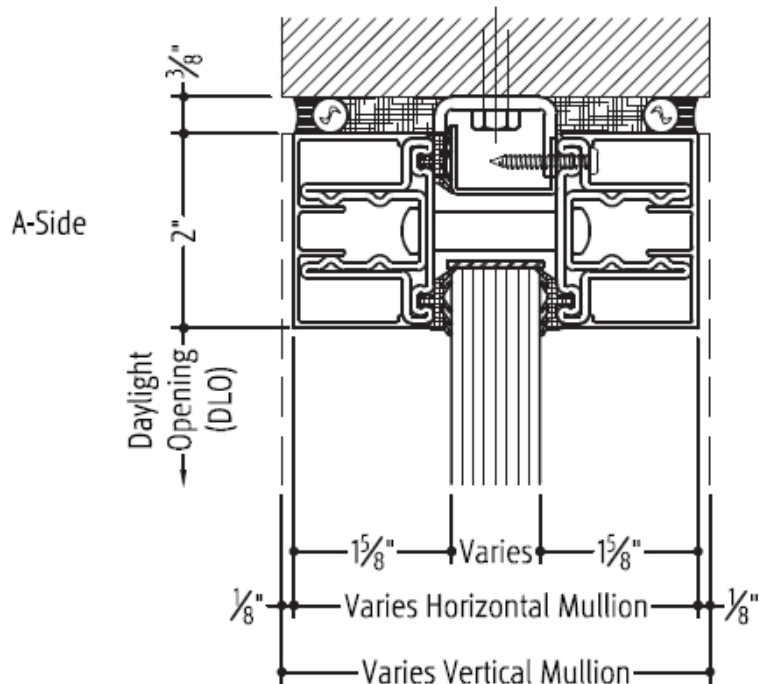

Non-Code Compliant Situations

- Non-tested assemblies
 - All components must have a complete laboratory listing
 - Fire-rated skylights (systems tested vertically but installed sloped)
- Assemblies must be installed EXACTLY as tested
 - Film on fire-rated glazing must be tested and approved
 - Wood trim or other combustibles on a fire-rated frame
- Improperly tested products
 - Non-accredited testing lab
 - Partial testing of a product...i.e. non hose stream over 20 minutes
 - Products that only provide impact or fire rating in one directions

Selecting Fire-Rated Glazing

Questions:

- What is the required fire-rating for the application?
- Does the glazing system need to block the transfer of radiant heat?
- Does the glazing meet impact safety standards?
- Should I select performance films or laminates?
- Are there any acoustic or thermal performance needs?
- Is the glazing being installed into the proper framing assembly (matched fire-ratings)?
- Once the glazing has been selected, did you confirm the material has been tested by a testing agency such as UL and can be validated through that testing agency?

Case Studies



Project: University Hospitals, Seidman Cancer Center

Location: Cleveland, OH

Architect: Cannon Design

Products: Fireframes® Designer Series steel doors and frames with FireLite Plus® glass ceramic



Case Studies



Project: MultiCare Good Samaritan Hospital,
Dally Tower

Location: Puyallup, WA

Architect: Good Sam Design Collaborative, in
conjunction with Clark/Kjos Architects and GBJ
Architecture

Products: Fireframes® Curtainwall Series with
Pilkington Pyrostop® glass firewall

When facing a decision that affects life safety, make sure the systems used meet all code requirements. Not all products are created equal.



Thank you!