

# Life Safety Dampers

Fire, Smoke, Combination Fire Smoke



# Agenda

- ▶ **Installation/Configuration**
  - Fire Dampers
  - Smoke Dampers
  - Combination Fire/Smoke Dampers
- ▶ **Operational Test/Inspection**
- ▶ **Periodic Test/Maintenance**



# Damper Selection

- **Comply with code requirements**
- **Design for long term use**
- **Modification restrictions**



# What makes an approved system?

- ▶ **Barrier**
- ▶ **Product**
- ▶ **Installation**

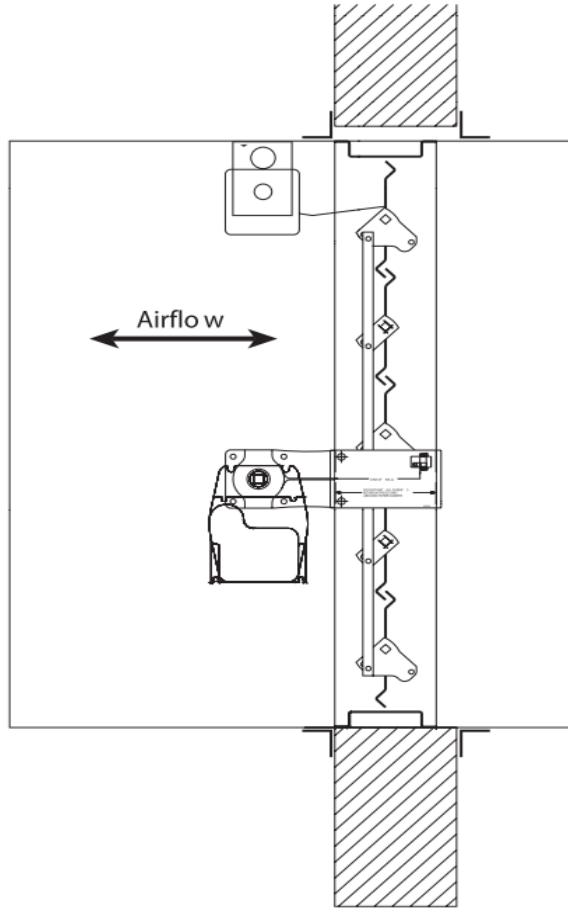

# Barrier First – I503



# What is it?

## ► Labels



# Is it right?

UL | Online Certifications Directory - Search Results - Microsoft Internet Explorer

Address: http://database.ul.com/cgi-bin/XYV/cgfind.new/LISEXT/1/FRAME/srchres.html?collection=/data3/venty\_collections/lisext&dkhome=/data3/venty\_sw\_rev2<

**Underwriters Laboratories Inc.**

Number of hits: 39

Previous Page

[Refine Your Search](#) · [Home](#)

Company Name	Category Name	Link to File
ACME ENGINEERING & MFG CORP	Dampers for Fire Barrier and Smoke Applications	<a href="#">EMME.R16596</a>
ACTION AIR USA, DIV OF TOMKINS	Dampers for Fire Barrier and Smoke Applications	<a href="#">EMME.R16693</a>
AIR BALANCE INC	Dampers for Fire Barrier and Smoke Applications	<a href="#">EMME.R4708</a>
AMERICAN WARMING & VENTILATING	Dampers for Fire Barrier and Smoke Applications	<a href="#">EMME.R16398</a>
ARLAN DAMPER CORP	Dampers for Fire Barrier and Smoke Applications	<a href="#">EMME.R8610</a>
ARROW UNITED INDUSTRIES, DIV OF MESTEK	Dampers for Fire Barrier and Smoke Applications	<a href="#">EMME.R19235</a>
BUCKLEY ASSOCIATES INC	Dampers for Fire Barrier and Smoke Applications	<a href="#">EMME.R9491</a>
C&S AIR PRODUCTS	Dampers for Fire Barrier and Smoke Applications	<a href="#">EMME.R14981</a>
CESCO PRODUCTS	Dampers for Fire Barrier and Smoke Applications	<a href="#">EMME.R6462</a>
GREENHECK FAN CORP	Dampers for Fire Barrier and Smoke Applications	<a href="#">EMME.R13317</a>
GULF MECHANICAL ACOUSTIC MFG CO	Dampers for Fire Barrier and Smoke Applications	<a href="#">EMME.R20671</a>
HART & COOLEY INC	Dampers for Fire Barrier and Smoke Applications	<a href="#">EMME.R16751</a>
HERCULES INDUSTRIES INC	Dampers for Fire Barrier and Smoke Applications	<a href="#">EMME.R9356</a>

start | Microsoft ... | Microsoft Exce... | CAPS | Out | Microsoft Pow... | UL | Online Ce... | 2:37 PM

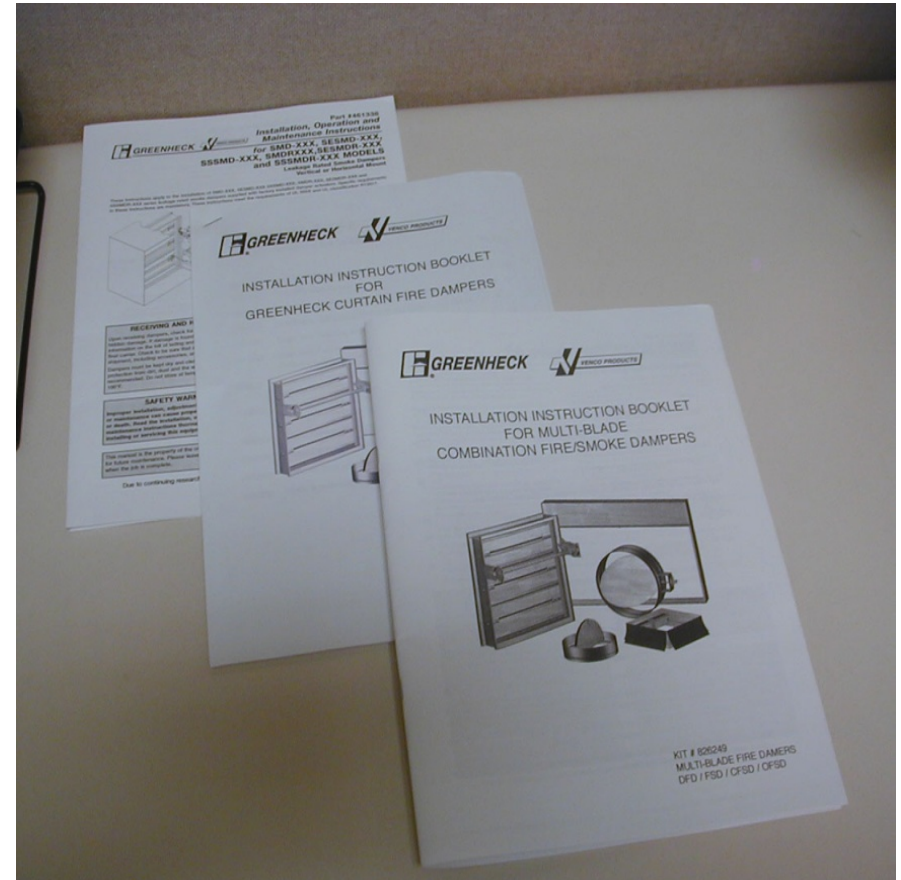



# Damper Categories

Three primary types of classified dampers

- Fire
- Smoke
- Ceiling Radiation

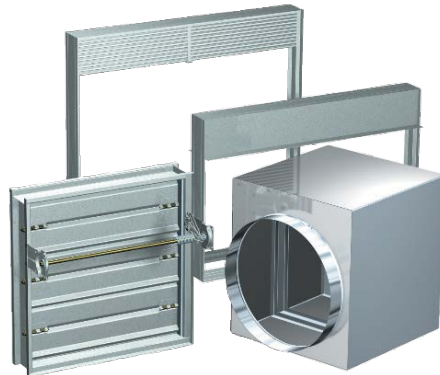

Fire Dampers



Combination Fire Smoke Dampers



Ceiling Radiation Dampers



Smoke Dampers

# UL 555: Fire Dampers

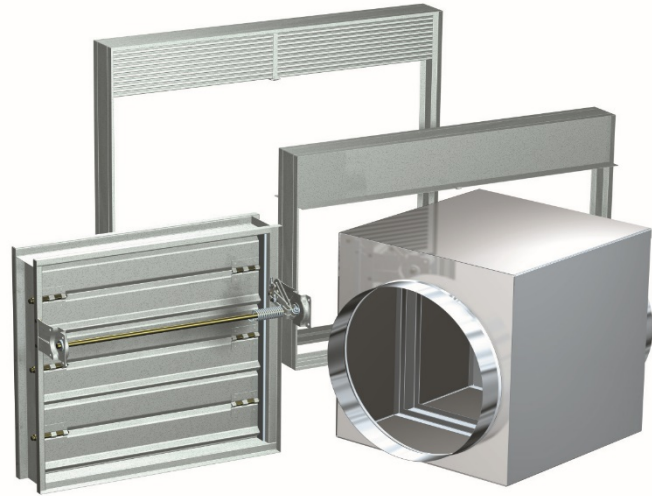

# UL 555 Classifications

## ▶ Static

- For use in HVAC systems that shut off in case of a fire emergency.



## ▶ Dynamic

- For use in HVAC systems that continue running during a fire emergency.
- Dynamic airflow test
- Increments of 1000 fpm



# Damper Construction

## ▶ Type

- Curtain
- Multi-blade
  - Blade Type

## ▶ Material

- Galvanized
- 304 stainless steel
- 316 stainless steel

## ▶ Mounting

- Vertical
- Horizontal



# Damper Ratings

- ▶ **Closure Temperature**
  - 165° F (160 minimum per IBC)
  - 350° F (maximum per IBC)
- ▶ **Operational Temperature**
  - 250° F (minimum)
  - 100° F increments

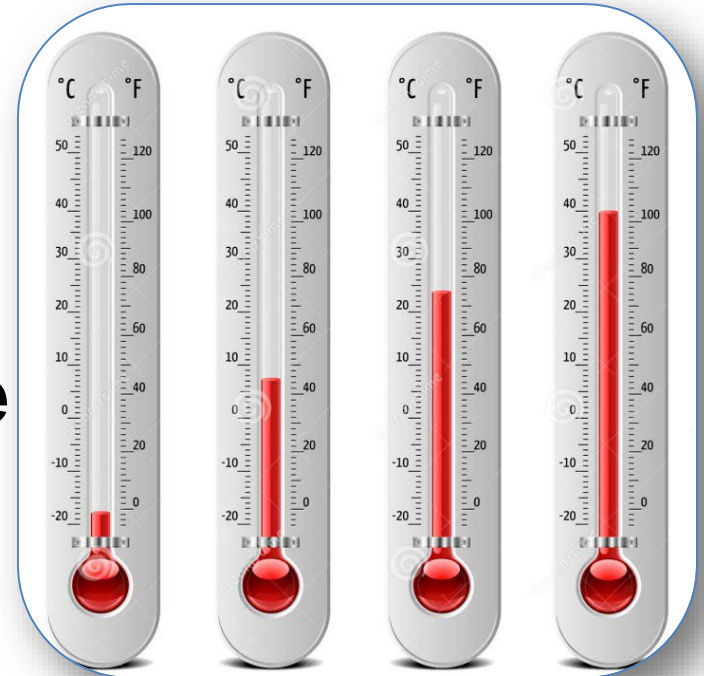

# Damper Ratings

## ▶ Operational Airflow Rating

- 2000 fpm
- 3000 fpm
- 4000 fpm
- +



## ▶ Operational Closure Pressure Rating

- 4 in. wg.
- 6 in. wg.
- 8 in. wg.
- +



# Combination Fire Smoke & Fire Dampers - Ratings

## ▶ IBC

- 717.3.2.1 Fire Protection rating. Fire dampers shall have the minimum fire protection rating specified in table for the type of penetration.

Type of Penetration	Minimum Damper Rating (hours)
Less than 3-hour fire resistance rated assemblies	1.5
3-hour or greater fire resistance rated assemblies	3





# Fire Damper Selection

## ▶ System Requirements

- Dynamic vs Static
- Temperature
- Velocity/Pressure
- Size
- Mounting



# Mounting

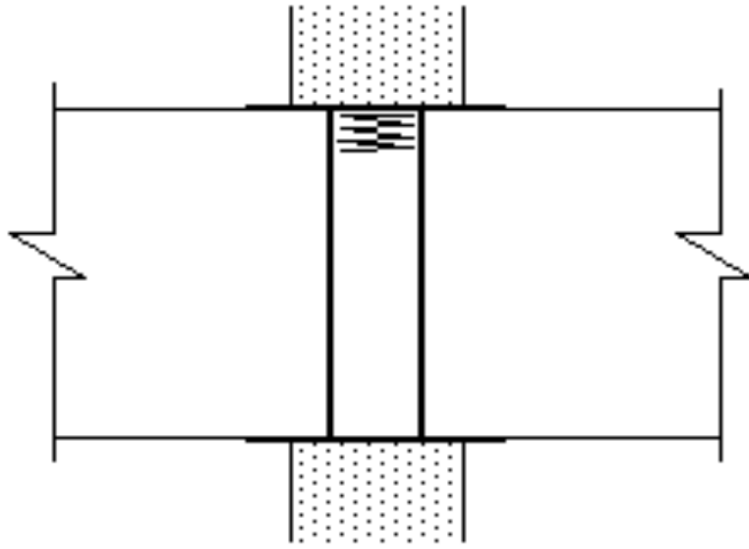

Vertical

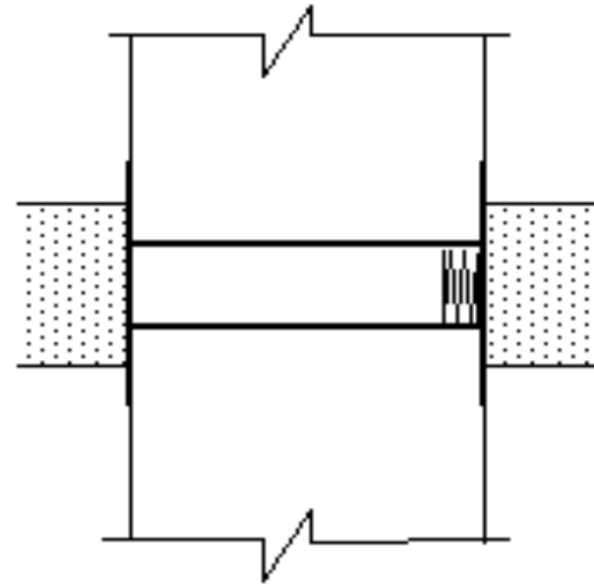

Horizontal

# Fire Damper Selection

## ▶ Performance

- Closure Device
- Controls
- Free Area
- Pressure Loss

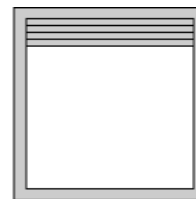
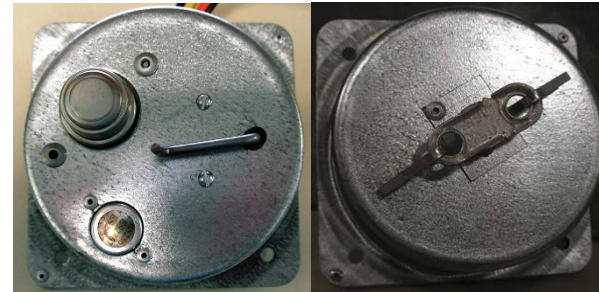

**Type A**  
Blades In Airstream

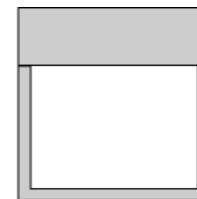

**Type B**  
Blades Out Of Airstream

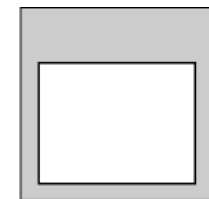

**Type C**  
100% Free Area

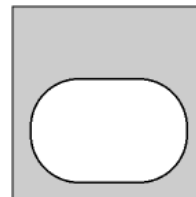

**Type CO**  
100% Free Area

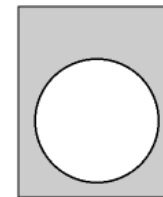

**Type CR**  
100% Free Area

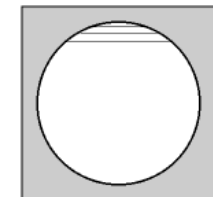

**Type R**  
High Free Area

# Installation Requirements

## Fire and Fire Smoke Dampers

### Framing of Opening

- Vertical studs must run floor to ceiling
- Double vertical studs over 36" x 36"
- Wood studs must be covered with sheet rock
- Steel studs do not need to be covered with sheet rock

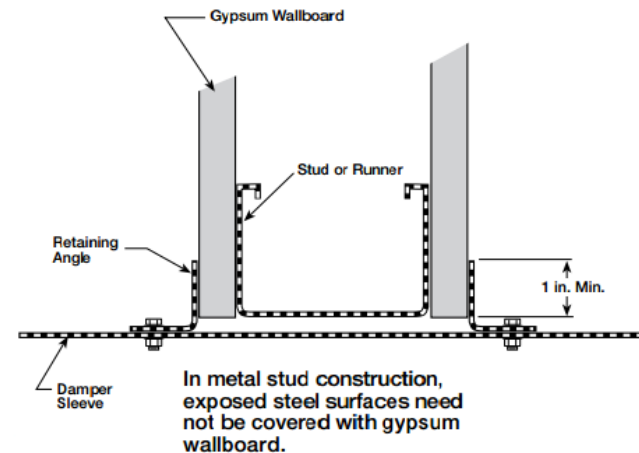
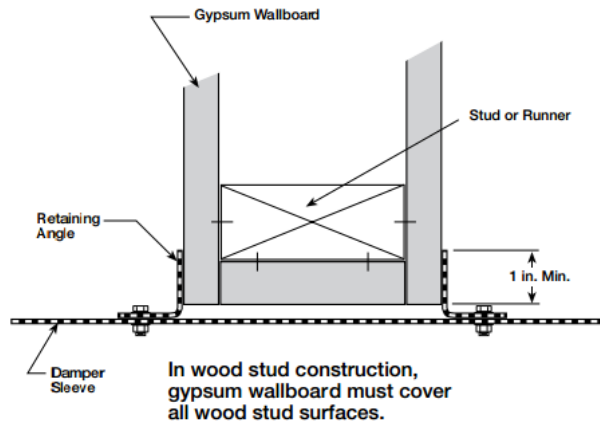
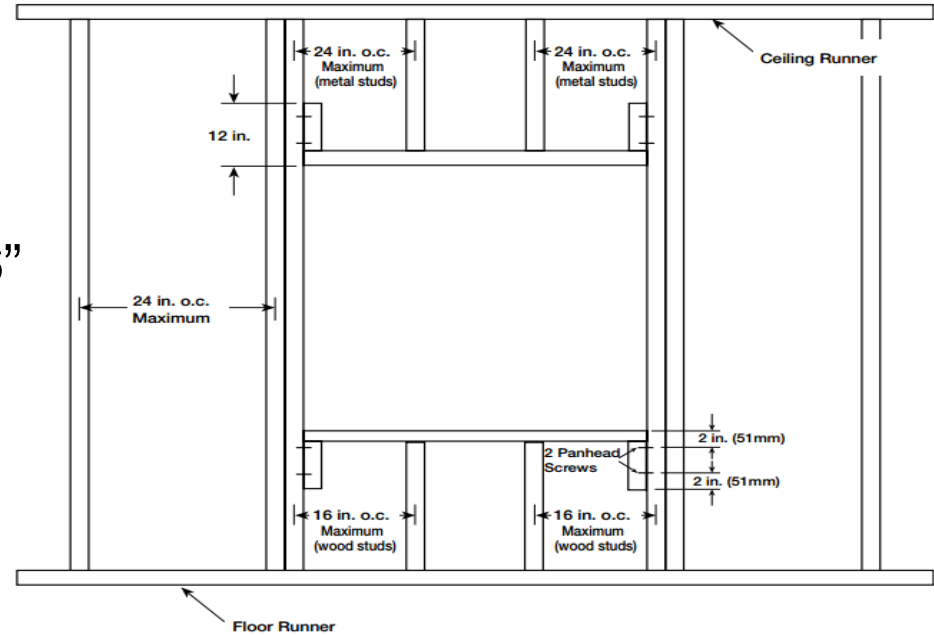

# Fire Damper Installation

## ► Installed with sleeves

- factory or field mounted
- sleeve requirements

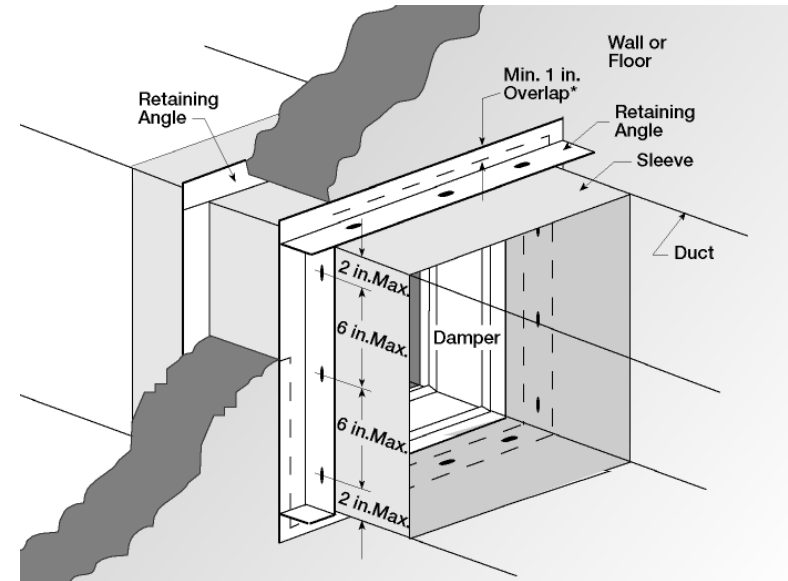

# Installation Requirements

## Fire and Fire Smoke Dampers

### Traditional Installation

1. The centerline of the damper frame must be in the plane of the wall/floor
2. Annular Space Requirements

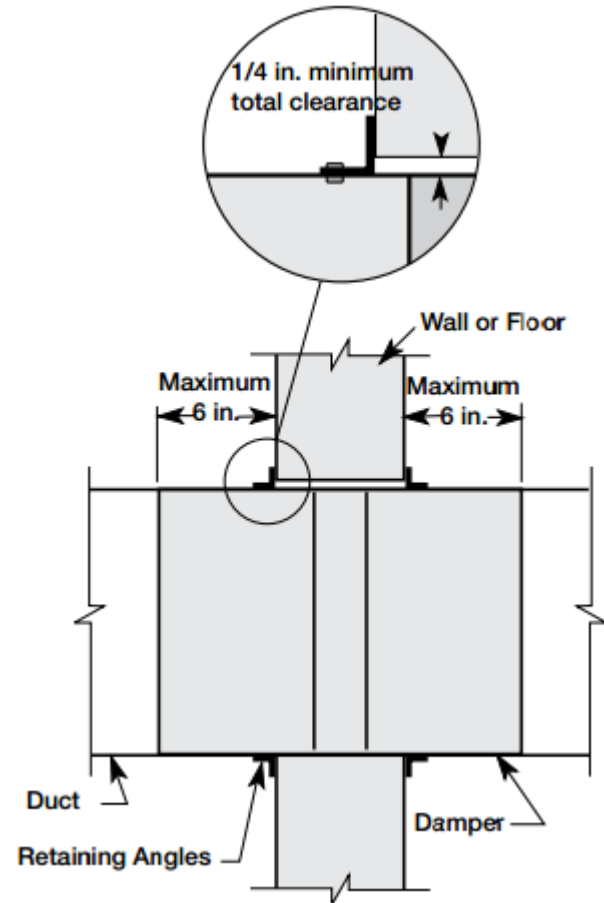



# Installation Requirements

## Fire and Fire Smoke Dampers

### Alternate Installation

1. Single Side Angle
2. 3 Sided Angle

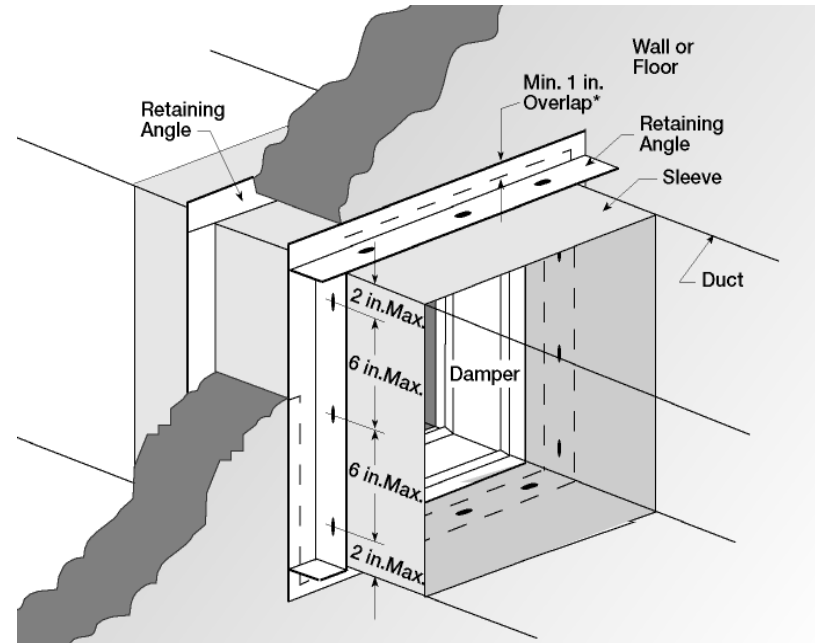
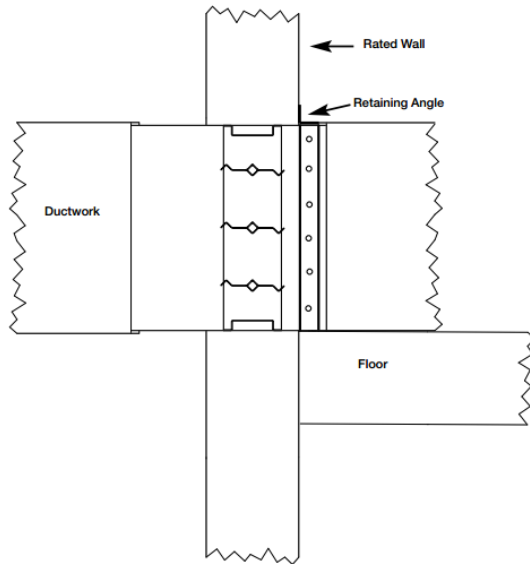



# Installation Requirements

## Fire and Fire Smoke Dampers

### Out-Of-Wall Installations

Commonly used in shaft walls installations where there is no external access to the actuator.

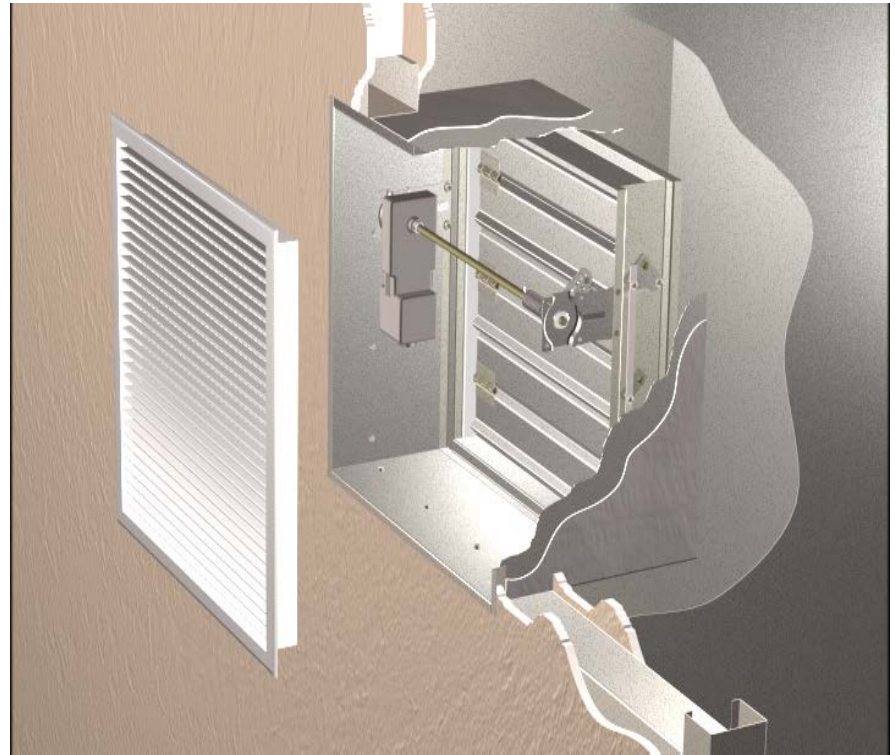
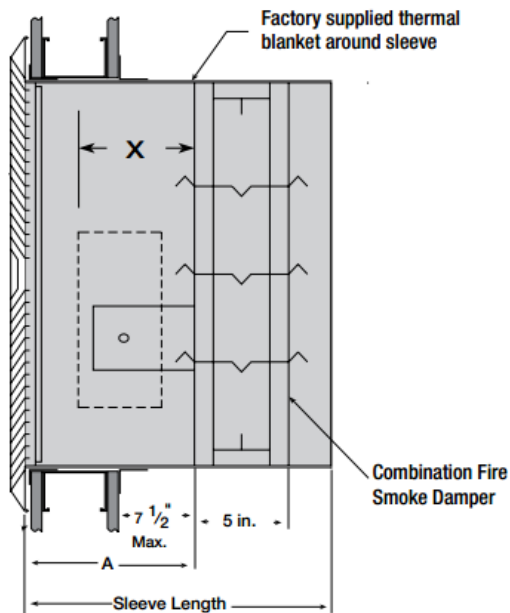

# Out-of-Wall Fire and Fire Smoke Dampers



# Out-of-Wall Fire and Fire Smoke Dampers



# Over-Sized Opening

- ▶ **Objective** - Protect a 160 x 94 ventilation penetration in a 2 hr rated barrier
- ▶ **Challenge** - The largest tested and listed damper system in the world for this application is 144 x 96
- ▶ **Solution** -



# Over-Sized Opening

## ▶ Static

- For use in HVAC systems that shut off in case of a fire emergency.

## ▶ Solution(s)

- Make smaller openings
- ▶ Same construction as barrier
- ▶ Mullion

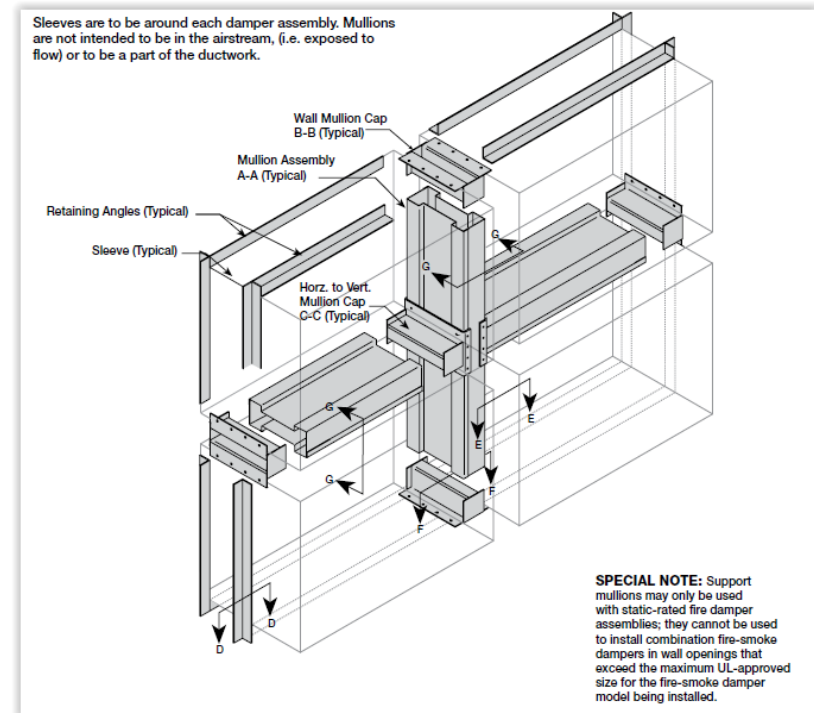

These installation instructions apply to the fabrication and construction of generic support mullions. Support mullions are necessary whenever static fire dampers are installed into a vertical opening that is larger than the largest UL rated size for that damper. The mullions allow construction of a fire barrier that is larger than the maximum available size.

Sleeves are to be around each damper assembly. Mullions are not intended to be in the airstream, (i.e. exposed to flow) or to be a part of the ductwork.

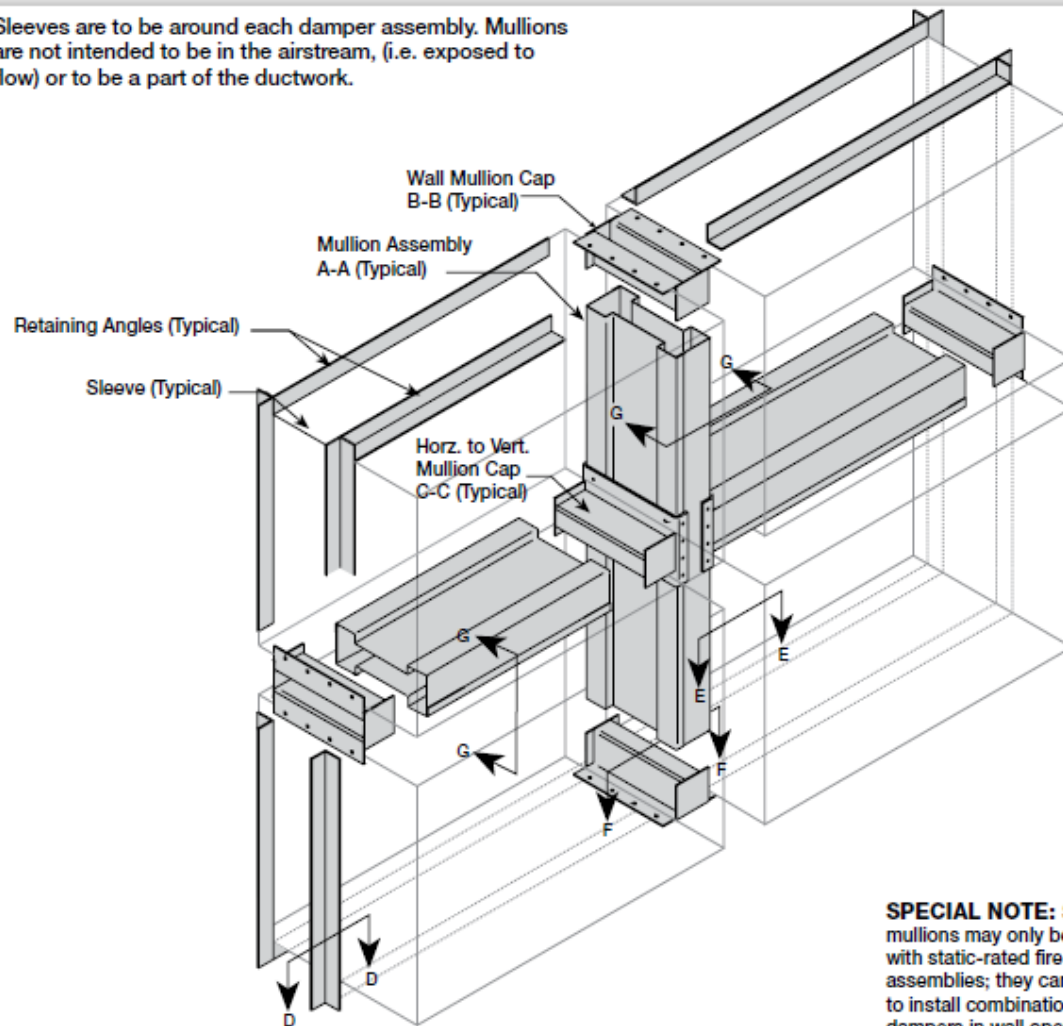

**SPECIAL NOTE:** Support mullions may only be used with static-rated fire damper assemblies; they cannot be used to install combination fire-smoke dampers in wall openings that exceed the maximum UL-approved size for the fire-smoke damper model being installed.

# Over-Sized Opening

## ▶ **Dynamic**

- For use in HVAC systems that continue running during a fire emergency.
- Dynamic airflow test
- Increments of 1000 fpm

## ▶ **Solution(s)**

- Much harder

- ▶ *Cannot exceed the velocity rating of the tested and listed system*

# 2,000 FPM (23 MPH)

Sleeves are to be around each damper assembly. Mullions are not intended to be in the airstream, (i.e. exposed to flow) or to be a part of the ductwork.

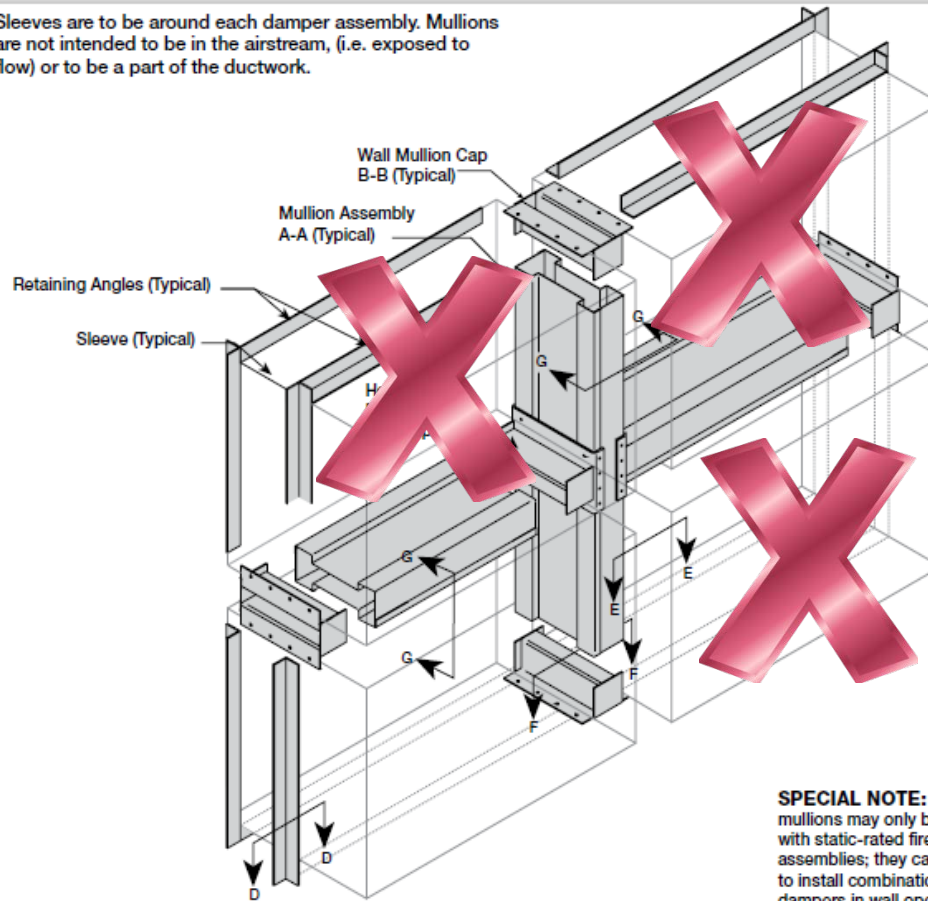

**SPECIAL NOTE:** Support mullions may only be used with static-rated fire damper assemblies; they cannot be used to install combination fire-smoke dampers in wall openings that exceed the maximum UL-approved size for the fire-smoke damper model being installed.

# 8,000 FPM (92 MPH)



# Installation Requirements

## Fire and Fire Smoke Dampers

### Traditional Installation

#### 4. Duct to Sleeve Connections

- Transverse Joints
- TDC/TDF
- Manufactured Systems
- Rigid Connection (when allowed)

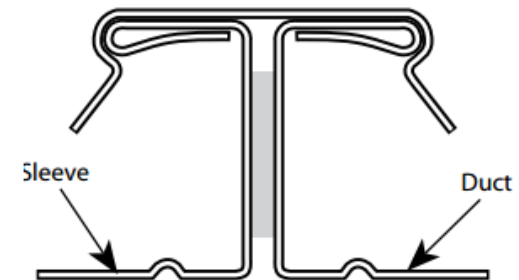
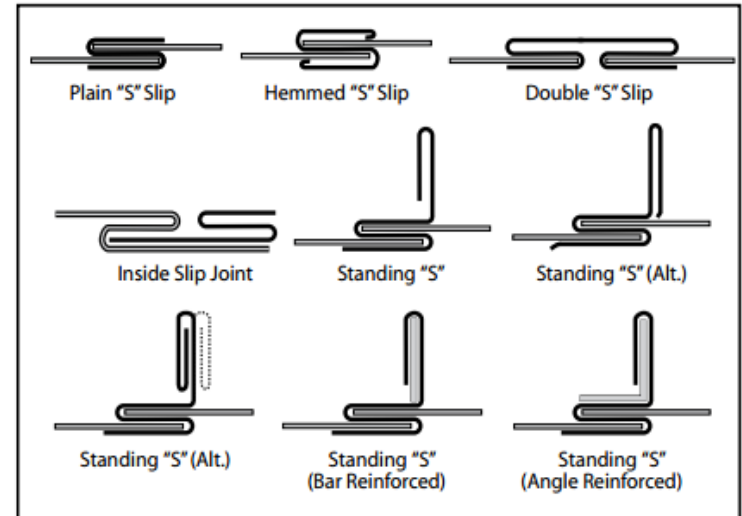
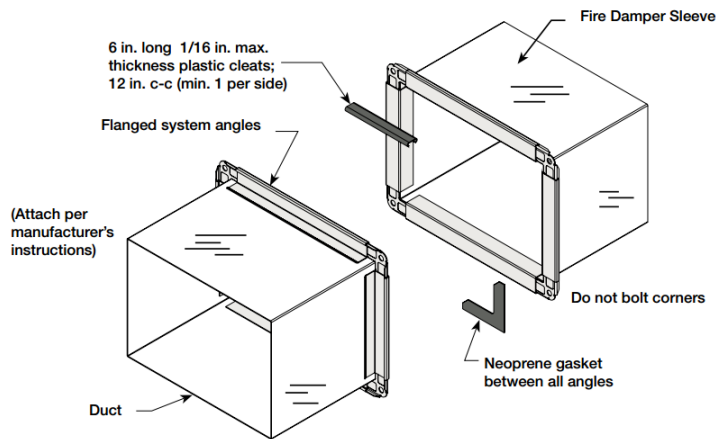

Typical TDC/TDF joint

# **Greenheck Connect-All Breakaway Test**

# Code Mandated Applications of Life-Safety Damper

## Sections 717.4 – Access Requirements

- An approved means of access large enough to permit inspection and maintenance of the damper and its parts shall be provided.
- Access opening shall not affect the fire resistance rating of the assembly

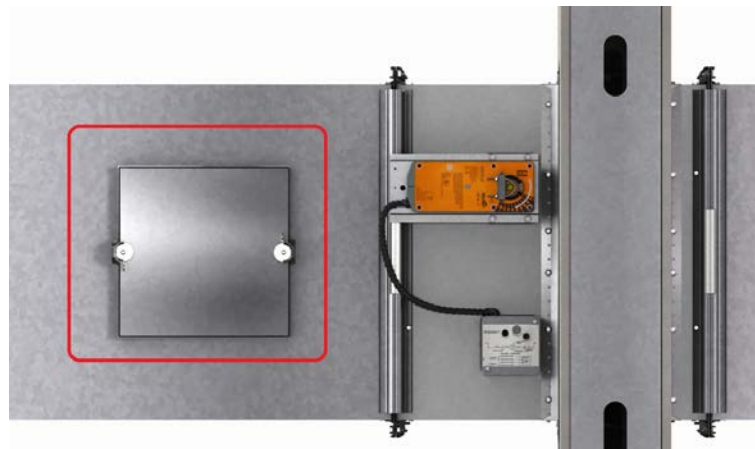

# UL 555S: Smoke Dampers



# Smoke Damper Construction

## ▶ Type

- multi-blade
- 3-V or airfoil blade

## ▶ Construction

- blade and jamb seals
- *always* with a UL-approved actuator



# Smoke Damper Actuators

## ▶ Mounting

- must be factory mounted
- internal or external

## ▶ Operation

- spring return
- two position or modulating



# UL 555S Classifications

## ▶ Leakage Class

- I (8 cfm/sq. ft @ 4 in.wg)
- II (20 cfm/sq. ft @ 4 in.wg)
- III (80 cfm/sq. ft @ 4 in.wg)

## ▶ IBC 716.3.2

- Smoke damper leakage ratings shall not be less than Class II.

## ▶ Operational Temperature

- Maximum operating temperature for damper
- 250° F
- 350° F

# Amount of Time to Fill a Room with Smoke Based on Leakage Class

<b>Leakage Class</b>	<b>Length of Time</b>
I	= 100 minutes
II	= 40 minutes
III	= 10 minutes

24"x 24"  
(610mm x 610mm)  
Damper

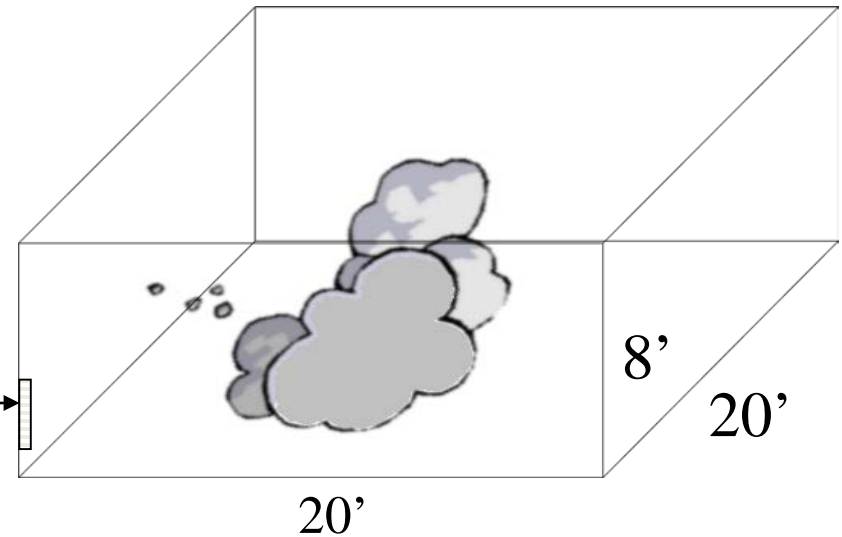



# Combination Fire/Smoke Dampers

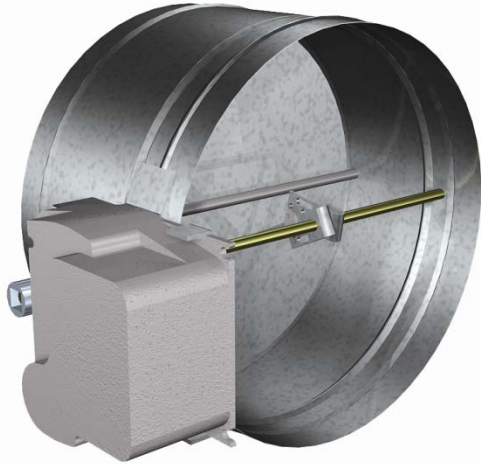

# Purpose of Fire/Smoke Damper

- ▶ Provide the same level of protection as individual fire and smoke dampers.
- ▶ Installation guidelines of fire and smoke dampers apply.



# Fire Smoke Installation

## ▶ Actuators

- UL-certified actuators
- installed at factory

## ▶ Operation

- spring return
- two position or modulating



# Fire/Smoke Damper Closure Devices

- ▶ **Fuse Link**
- ▶ **Electronic Link**
  - bi-metallic sensor
  - wired in series with actuator
  - cuts power to actuator when temperature is reached
  - resettable

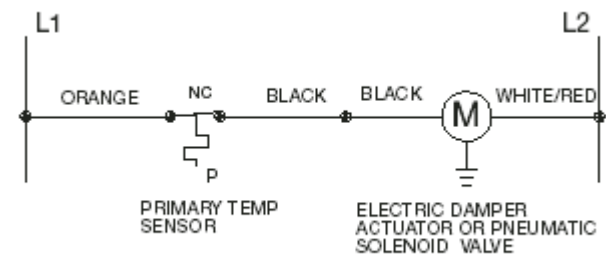

# Operational Test

## NFPA 80

### Standard for Fire Doors and Other Opening Protectives

#### Frequency

“After the installation of a damper is completed, an operational test shall be conducted.”

#### Test Method

“The damper shall fully close from the open position.”

“The operational test shall verify that there is full and unobstructed access to the fire damper and all listed components.”

“All indicating devices shall be verified to work and report to the intended location.”

“The operational test shall be conducted under non-fire HVAC airflow conditions as well as static flow conditions.”

# Operational Test

## NFPA 105

### Standard for the Installation of Smoke Door Assemblies and Other Opening Protectives

#### Frequency

“An operational test shall be conducted after the building’s HVAC system has been balanced.”

#### Test Method

“The operational test shall be conducted under normal HVAC airflow conditions as well as static flow conditions. The damper shall fully close/seal under both test conditions.”

“All indicating devices shall be verified to work properly and report to the intended location.”

“Combination fire/smoke dampers shall also meet the testing requirements contained in NFPA 80.”



# Importance of Inspection

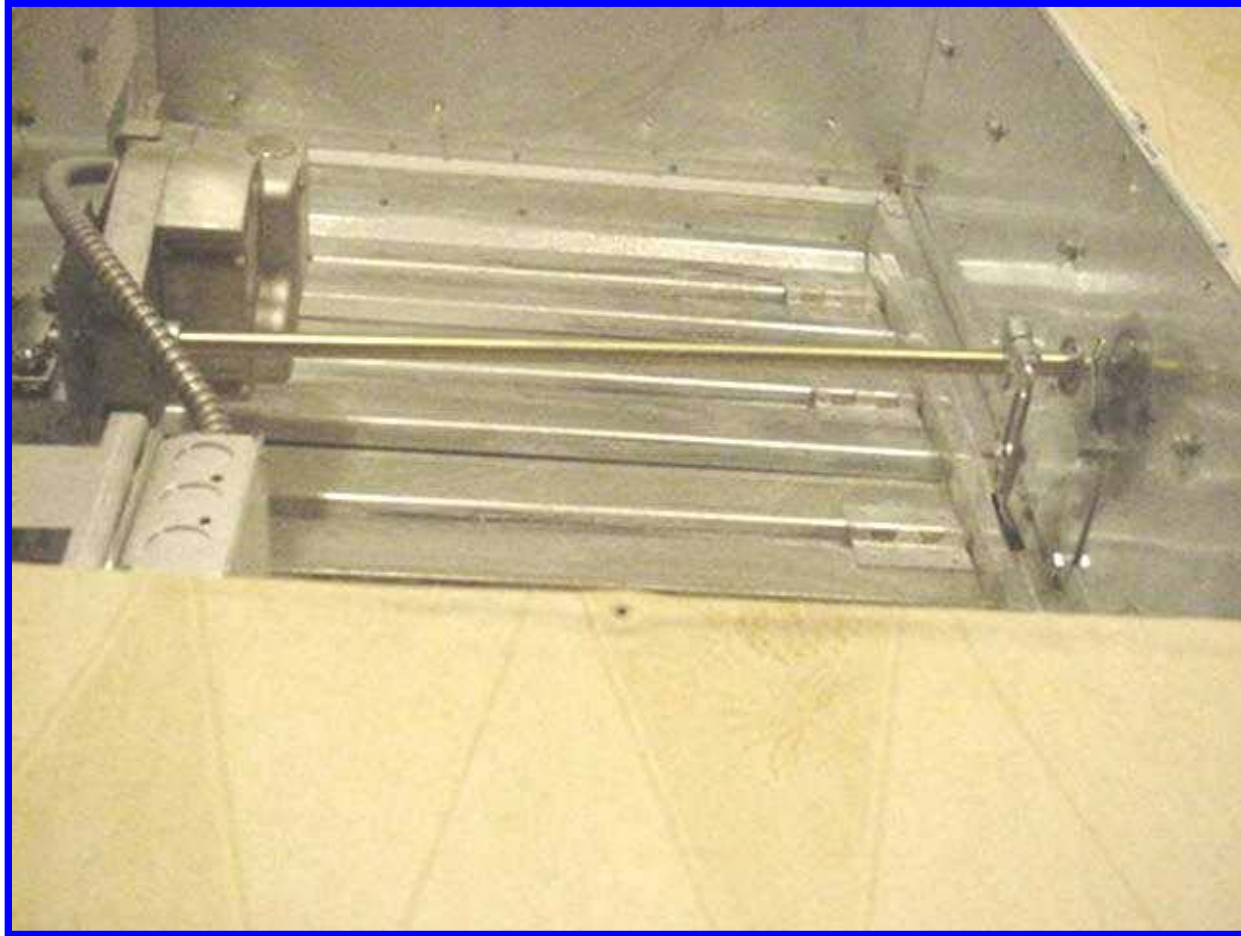

# Importance of Inspection





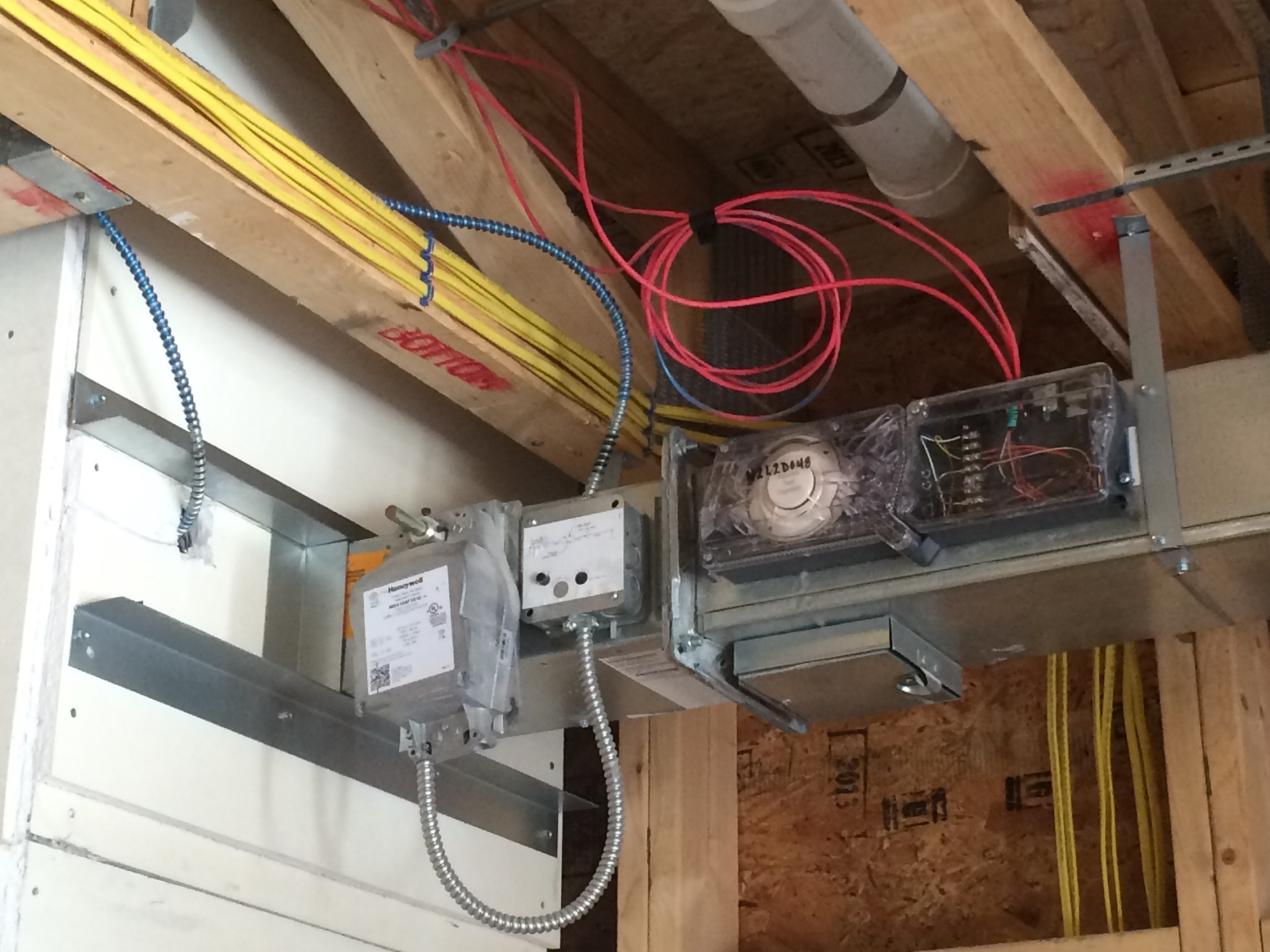

Honeywell  
MOTOR  
MOTOR

M2L2D048

MOTOR

2013

# Importance of Inspection



# Importance of Inspection



# Period Tests/Maintenance

# Importance of Maintenance

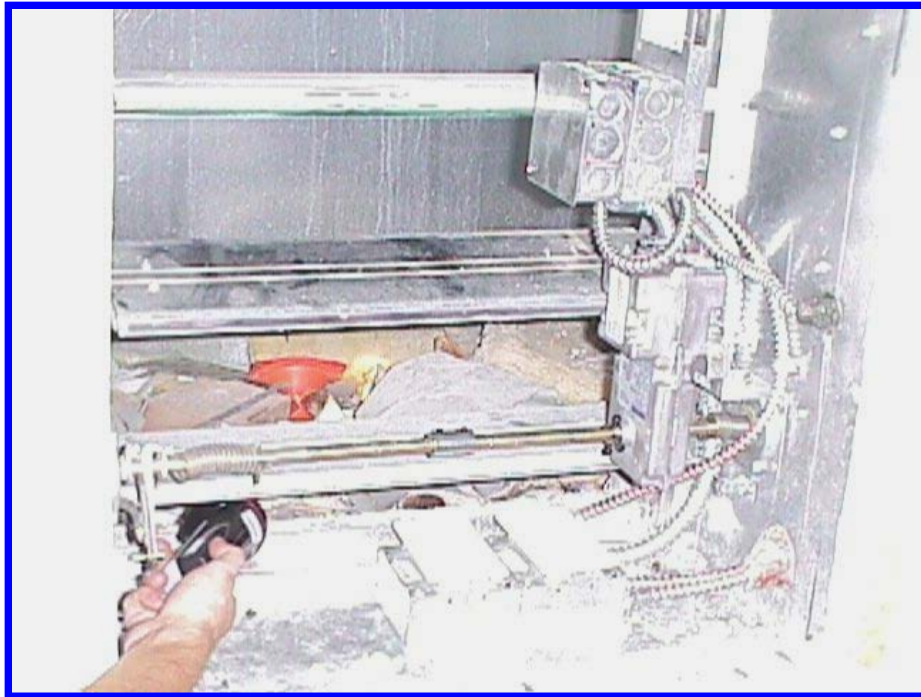

**Garbage placed inside of damper.**

# Periodic Testing Requirements

## International Fire Code (IFC)

### Smoke Dampers

“All openings protected with approved smoke barrier doors or smoke dampers shall be maintained in accordance with NFPA 105.”

### Fire Dampers

“All openings protected with approved doors or fire dampers shall be maintained in accordance with NFPA 80”.

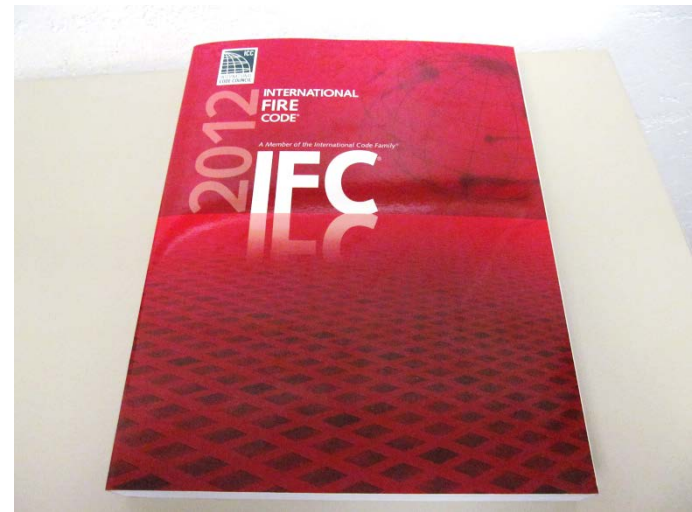

# Periodic Testing Requirements

## NFPA 80

### Standard for Fire Doors and Other Opening Protectives

#### Frequency

“Each damper shall be tested and inspected 1 year after installation” and then “every 4 years, except in hospitals, where the frequency shall be every 6 years.”

#### Test Method

“If the fire damper is equipped with a fusible link, the link shall be removed for testing to ensure full closure.”

“The operational test of the damper shall verify that there is no damper interference due to rusted, bent, misaligned, or damaged frame or blades.”



# Periodic Testing Requirements

## NFPA 80

### Standard for Fire Doors and Other Opening Protectives

#### Maintenance

“All exposed moving parts of the damper shall be dry lubricated as required by the manufacturer”

“If the damper is not operable, repairs shall begin without delay”

“Following any repairs, the damper shall be test for operation in accordance with Section 19.4(Inspection and Testing)





# Periodic Testing Requirements

## NFPA 105

### Standard for the Installation of Smoke Door Assemblies and Other Opening Protectives

#### Frequency

“Each damper shall be tested and inspected 1 year after installation” and then “every 4 years, except in hospitals, where the frequency shall be every 6 years.”

#### Test Method

“If the fire damper is equipped with a fusible link, the link shall be removed for testing to ensure full closure.”

“The operational test of the damper shall verify that there is no damper interference due to rusted, bent, misaligned, or damaged frame or blades.”



# Periodic Testing Requirements

## NFPA 105

### Standard for the Installation of Smoke Door Assemblies and Other Opening Protectives

#### Maintenance

“All exposed moving parts of the damper shall be dry lubricated as required by the manufacturer.”

“If the damper is not operable, repairs shall begin without delay.”

“Following any repairs, the damper shall be test for operation in accordance with Section 6.5(Inspection and Testing).”



# Periodic Testing Requirements

## Changes to the 2019 Editions of NFPA 80 & 105

### Periodic Testing for Dampers That Do Not Use a Fusible Link to Operate

#### Remote Inspection Method

##### Requirements for Utilizing the Remote Inspection Method

1. Shall positively indicate a dampers fully-open and fully-closed position
2. The initial inspection shall include a visual inspection of the damper in accordance with 19.5.2.3.2
3. The visual inspection shall confirm that the position indication method accurately reflects the full-open and fully-closed position of the damper

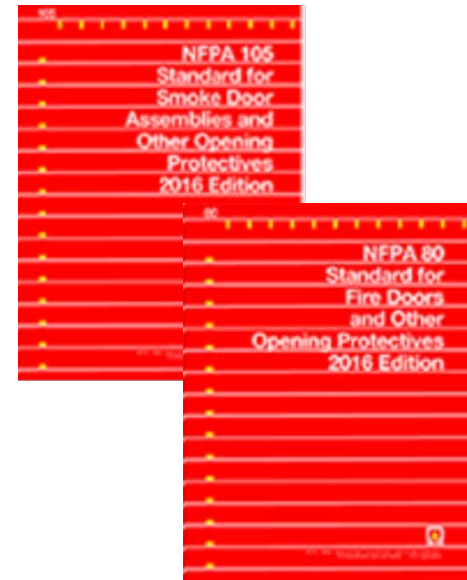

# Periodic Testing Requirements

## Changes to the 2019 Editions of NFPA 80 & 105

### Periodic Testing for Dampers That Do Not Use a Fusible Link to Operate

#### Remote Inspection Method

##### Remote Test Procedure

1. Use the position indication functionality to confirm that the damper is in it's intended normal position (typically open)
2. Command the damper to the position opposite its normal position (typically closed). Use the position indication device to confirm that the damper has moved reached that position
3. Command the damper back to it's original position and use the position indication device to confirm that it has reached that position
4. If the damper fails to comply with steps 1 thru 3 a visual inspection must be conducted.



# Installation Books

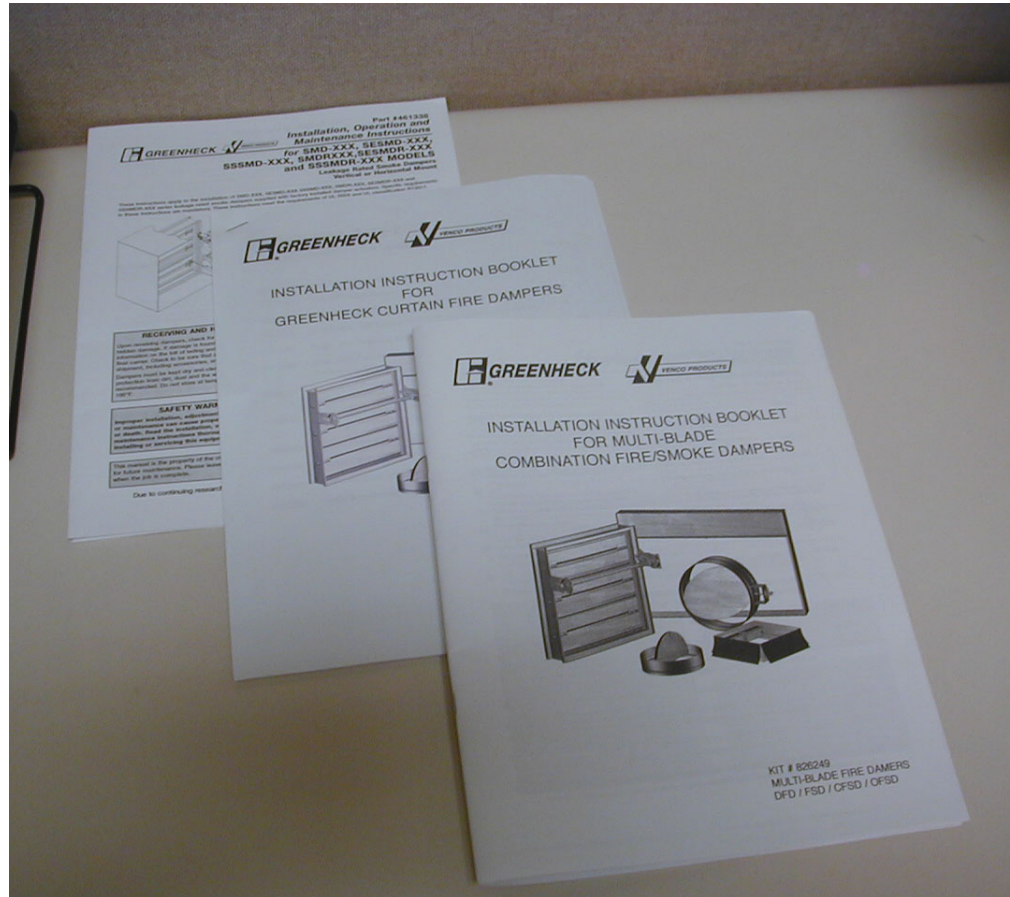

**Thank You**